



The following are registered trademarks of Brunswick Corporation: Merc, MerCathode, Mercury MerCruiser, Mercury, Mercury Marine, Quicksilver, Ride-Guide, Thruster and Mercury Precision Parts.

GASOLINE ENGINE STERNDRIVE MODELS INSTALLATION MANUAL

Models Covered

Alpha

Model	Serial Number or Year
3.0L	0M093621 and Above
4.3L	
5.0L	
5.7L	

Bravo

Model	Serial Number or Year
4.3L	0M093633 and Above
5.0L	
5.7L	

Notice

NOTICE
After completing installation, these instructions should be placed with the product for the owner's future use.

NOTICE
Predelivery preparation instructions must be performed before delivering boat to the product owner.

Table Of Contents

General Information	3	Alpha or Bravo Models Using	
Notice to Boat Manufacturer/Installer	3	Alternative Water Pickups	63
Torque Specifications	4	Coolant Recovery System	66
Lubricants / Sealants / Adhesives	5	Shift Cable Installation	67
Special Tools	6	Alpha Models - Drive Unit Not	
Alpha Notice: Increased Trim-In Range		Installed	67
Capability	6	Bravo Models	72
Bravo Three Notice: Trim-In Limit Insert	7	Throttle Cable Installation and	
Quicksilver Products	7	Adjustment	76
Accessories	7	Sterndrive Unit Installation	77
Serial Number Decal Placement	8	Alpha Models	79
Corrosion Protection	8	Bravo Models	82
Anti-fouling Paint	9	All Models	86
Boat Construction	10	Speedometer Connection	87
Transom Thickness and Surface	10	Alpha Models	87
Engine Bed	11	Bravo Models	88
Crankshaft Vertical Centerline	11	Shift Cable Installation	89
Crankshaft Horizontal Centerline		Alpha Models - Drive Unit Installed	89
(X-Dimension)	12	Troubleshooting Shift Problems	95
Transom Cutout	14	Predelivery Preparation	98
Seawater Connections - General		Power Steering Fluid	98
Information	16	Filling Coolant Recovery Bottle	99
Seawater Pickup	16	Power Trim Pump	99
Preliminary Connections	18	Trim Position Sender Adjustment	100
Power Trim Pump	18	Propeller Selection	101
Fuel Inlet Fitting	19	Propeller Installation	102
Transom Connections	20	Battery	106
Installing Gimbal Housing	20	Test Running Engine	107
Installing Inner Transom Plate	21	Boat In The Water Tests	111
Connecting Speedometer Pickup	22	Cold Weather and Extended Storage	114
Fluid Connections	23	Draining Instructions	114
Installing Steering System	25	3.0L Single Point Drain	115
Transom Preparation	35	V6 And V8 Seawater (Raw-Water)	
Driveshaft Extension Models	39	Cooled Models	119
Engine Preparation	39	V6 And V8 Closed Cooled Models	122
Engine Installation	40	All Models	124
Exhaust System	43	Wiring Diagrams	126
Methods for Measuring Exhaust		Instrumentation	126
Elbow Height	46	Power Trim System	128
Exhaust System Hose / Tube		MerCathode System Wiring Diagram	129
Connections	48	MCM Gasoline Engine Wiring Diagrams ...	130
Engine Alignment	49	3.0L Engines	130
Hot Water Heater Installation	53	MCM 4.3L, 5.0L And 5.7L Alpha	
Electrical Connections	55	Engines	131
Installing Continuity Wire	55	MCM 4.3L Bravo Engines	132
Instrumentation Connections	56	MCM 5.0L and 5.7L Bravo Engines	133
Trim Position Sender Connections	57	Water Flow Diagrams	134
MerCathode Connections	57	181 cid / 3.0L Engines	134
Audio Warning System Connections	58	V8 Engines - Seawater Cooled	135
Power Trim Pump Connections	59	V6 and V8 Engines - Closed Cooled ...	136
Fluid Connections	61	Predelivery Inspection	137
Gear Lube Monitor Hose	61		
Power Steering Hoses	62		
Bravo Models and Alpha Seawater			
Cooled Models Using Sterndrive			
Water Pickups	62		

General Information

Notice to Boat Manufacturer/Installer

Throughout this publication, Warnings and Cautions (accompanied by the International Hazard Symbol ) are used to alert the manufacturer or installer to special instructions concerning a particular service or operation that may be hazardous if performed incorrectly or carelessly. — **Observe Them Carefully!**

These Safety Alerts, alone, cannot eliminate the hazards that they signal. Strict compliance to these special instructions when performing the service, plus common sense operation, are major accident prevention measures.

WARNING

Hazards or unsafe practices which could result in severe personal injury or death.

CAUTION

Hazards or unsafe practices which could result in minor personal injury or product or property damage.

IMPORTANT: Indicates information or instructions that are necessary for proper installation and/or operation.

NOTE: Refer to the Mercury MerCruiser Product Applications Manual - Gasoline Sterndrive Models for application recommendations.

This installation manual has been written and published by Mercury Marine to aid the boat manufacturer (OEM) in the installation of the products described herein.

It is assumed that these personnel are familiar with marine product installation. Furthermore, it is assumed that they are familiar with, if not trained in, the recommended installation procedures of Mercury MerCruiser product.

We could not possibly know of or advise the marine trade of all conceivable installations and of the possible hazards and/or results of each installation. Therefore, the OEM is responsible for any installation that does not fulfil the requirements of this manual.

It is the responsibility of the boat manufacturer to select the appropriate engine/transom/drive package (including the correct gear ratio and propeller) for a given boat. Mercury recommends that any new or unique hull/power package combination be thoroughly water tested prior to sale, to verify that the boat performs as desired, and that the engine runs in the appropriate rpm range.

It is recommended that a Mercury Marine Sales Application Engineer (SAE) be contacted for assistance.

All information, illustrations and specifications contained in this manual are based on the latest product information available at time of publication. As required, revisions to this manual will be sent to all OEM boat companies.

Torque Specifications

NOTE: Securely tighten all fasteners not listed below.

Description	Nm	lb-in.	lb-ft
Gear Lube Monitor Fitting	9	80	
Speedometer Pickup Barb Fitting	1.5	13	
Exhaust Pipe or Block-off Plate	31		23
Power Steering Hydraulic Hose Fittings	31		23
Power Trim Pump Hose Fittings	14	125	
Propeller Nut Alpha One, Bravo One and Bravo Two ¹	75		55
Front Propeller Nut Bravo Three	136		100
Rear Propeller Nut Bravo Three	81		60
Rear Engine Mounts	51		38
Steering Cable Coupler Nut	48		35
Steering System (Pivot Bolts)	34		25
Sterndrive Unit Fasteners	68		50
Transom Assembly Fasteners	31		23
Seawater Pickup Fitting	5	45	
Fuel Inlet Fitting	Finger tight + 1-3/4 to 2-1/4 turns with a wrench. DO NOT overtighten.		

¹ Amount specified is MINIMUM.

Lubricants / Sealants / Adhesives

Description	Where Used	Part Number
Engine Coupler Spline Grease	Coupler Splines	92-816391A4
	Drive Unit Pilot	
	U-Joint O-rings	
	Drive Shaft Splines	
2-4-C Marine Lubricant With Teflon	Anchor Pins	92-825407A3
	Trim Cylinder Hardware	
	O-ring Seals	
	Shift Cable End	
Special Lubricant 101	Propeller Splines	92-13872A1
	Pivot Bolts	
	Power Steering Bushings	
	Clevis Pin	
Dexron III - Automatic Transmission Fluid	Steering Cable End	Obtain Locally
	Propeller Splines	
Power Trim and Steering Fluid	Power Steering Pump	92-90100A12
	Power Trim Pump	
Liquid Neoprene	Battery Terminals	92-25711-2
	MerCathode Connections	
Loctite 592 PST	Speedometer Barb Fitting	Obtain Locally
	Fuel Inlet Fitting	
	Seawater Inlet Hose Fitting Threads	
	Seawater Inlet Plastic Plug Threads	
Loctite 271	Seawater Inlet Nut	92-809820
SAE 30W Engine Oil	Power Trim Pump	Obtain Locally
	Shift Cable Pivot Points	
SAE 10W40 Engine Oil	Power Trim Pump	Obtain Locally
Marine Caulking	Seawater Inlet Mounting Surfaces	Obtain Locally
Power Tune	Exhaust Tubes	92-802878-57
Quicksilver High Performance Gear Lube	Sterndrive Unit	92-802853A1
Silicone Sealant Or Equivalent	Screw Shaft	Obtain Locally

Equivalent products may be used.

Special Tools

Description	Part Number
Transom Drilling Fixture	91-43693A2
Engine Alignment Tool	91-805475A1
Shift Cable Adjustment Tool	91-12427
Engine Mount Drilling Fixture	91-806794A1
Tapered Insert Tool	91-43579
Shift Shaft Slide Stabilizer Tool	91-809815A1

Alpha Notice: Increased Trim-In Range Capability

The Alpha trim cylinders provide the capability for an increased trim-in range. A spacer can be removed from the trim cylinders to increase the trim-in range by approximately 1-1/2 degrees. This will improve the acceleration on some boats by forcing the bow down more quickly. If the spacers are to be removed, the boat must be water tested to ensure that the increased trim-in range does not cause any undesired boat handling characteristics (bow-steer, chine-walk, etc.) if the sterndrive is trimmed in while the boat is operated at higher speeds. The boat should be tested under all conceivable load conditions and maneuvers to ensure that the additional trim-in does not pose a problem. The final decision and responsibility for use of the additional trim-in range is left up to the boat manufacturer.

WARNING

It is recommended that only qualified personnel adjust the Trim-In Limit Spacer. Boat must be water tested after adjusting or removing the device to ensure that the modified trim-in range does not cause the boat to exhibit an undesirable boat handling characteristic if the sterndrive unit is trimmed in at higher speeds. Increased trim-in range may cause handling problems on some boats that could result in personal injury.

Bravo Three Notice: Trim-In Limit Insert

NOTE: *Bravo One, Two and Three Models are equipped with a Trim-In Limit Insert.*

It has been brought to our attention that some boats (predominantly deep-Vee heavy boats) will roll up on their side under certain, specific, operating conditions. The roll can be either to port or starboard and may be experienced while moving straight ahead, or while making a turn. The roll occurs most frequently at or near maximum speed, with the sterndrive unit trimmed at or near full trim-in. While the boat will not roll completely over, the roll may be sufficient to unseat the operator or passengers, and thereby create an unsafe situation.

The roll is caused by stern-lift created from excessive sterndrive unit trim-in. Under these extreme stern-lift / bow-down conditions instability can be created which may cause the boat to roll. Weight distribution to the stern can reduce stern-lift and, in some circumstances, help to control the condition. Weight distribution in the bow, port or starboard, may worsen the condition.

The Trim-In Limit Insert reduces stern-lift by preventing the sterndrive unit from reaching the last few degrees of full trim under. While this device should reduce the rolling tendency, it may not eliminate the tendency entirely. The need for this Trim-In Limit Insert, and its effectiveness, can only be determined through boat testing and is ultimately the responsibility of the boat manufacturer.

WARNING

It is recommended that only qualified personnel adjust the Trim-In Limit Insert. Boat must be water tested after adjusting the device to ensure that the modified trim-in range does not cause the boat to exhibit an undesirable boat handling characteristic if the sterndrive unit is trimmed in at higher speeds. Increased trim-in range may cause handling problems on some boats which could result in personal injury.

Quicksilver Products

Accessories

Quicksilver gauges, remote controls, steering systems, propellers and other accessories are available for this product. Mercury MerCruiser recommends the use of Quicksilver parts on all applications. Refer to *Mercury Precision Parts / Quicksilver Accessories Guide* for a complete listing.

This Guide is available from:

Mercury Marine
Attn: Parts Department
W6250 W. Pioneer Road
P.O. Box 1939
Fond du Lac, WI 54936-1939

Outside of U.S.A., order through Distribution Center or Distributor.

Serial Number Decal Placement

There are three sets of engine, transom assembly and sterndrive serial number decal strips provided with each power package. One should be used for each of the following:

- Engine Specification Decal
- Warranty Registration Card
- Operation, Maintenance and Warranty Manual identification page.

Affix serial number decals to specification / serial number decal.

Corrosion Protection

Mercury MerCruiser power packages are equipped with anodes to help protect them from galvanic corrosion under moderate conditions. However, for severe conditions or if using a stainless steel propeller, it is recommended that a Quicksilver Anti-Corrosion Anode Kit and/or a MerCathode System be installed (some models have a MerCathode System as standard equipment). A MerCathode Monitor also is available to allow the operator to check the operation of the MerCathode System with the push of a button. (Refer to “Quicksilver *Mercury Precision Parts / Quicksilver Accessories Guide*” for part numbers.)

Boats which are connected to AC shore power require additional protection to prevent destructive low voltage galvanic currents from passing through the shore power ground wire. A Quicksilver Galvanic Isolator can be installed to block the passage of these currents while still providing a path to ground for dangerous fault (shock) currents. (Refer to *Mercury Precision Parts / Quicksilver Accessories Guide* for part number.)

IMPORTANT: If AC shore power is not isolated from boat ground, the MerCathode System and anodes may be unable to handle the increased galvanic corrosion potential.

Refer to Marine Corrosion Protection Guide P/N 90-881813 01 for specific information about marine corrosion.

Anti-fouling Paint

IMPORTANT: Corrosion damage that results from the improper application of anti-fouling paint will not be covered by the limited warranty.

Painting Boat Hull or Boat Transom: Anti-fouling paint may be applied to boat hull and boat transom but you must observe the following precautions:

IMPORTANT: DO NOT paint anodes or MerCathode System reference electrode and anode, as this will render them ineffective as galvanic corrosion inhibitors.

IMPORTANT: If anti-fouling protection is required for boat hull or boat transom, copper or tin base paints, if not prohibited by law, can be used. If using copper or tin based anti-fouling paints, observe the following:

- Avoid an electrical interconnection between the Mercury MerCruiser Product, Anodic Blocks, or MerCathode System and the paint by allowing a minimum of 1-1/2 in. (40 mm) UNPAINTED area on transom of the boat around these items.

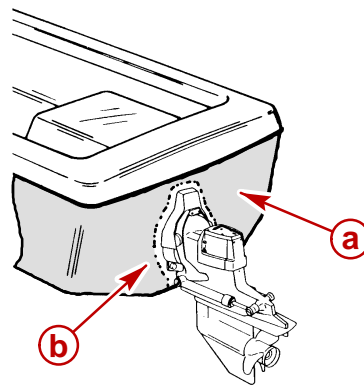

71176

a - Painted Boat Transom

b - Minimum 1-1/2 in. (40 mm) UNPAINTED Area Around Transom Assembly

NOTE: Sterndrive unit and transom assembly can be painted with a good quality marine paint or an anti-fouling paint that DOES NOT contain copper, tin, or any other material that could conduct electrical current. Do not paint drain holes, anodes, MerCathode system or items specified by boat manufacturer.

Boat Construction

Transom Thickness and Surface

IMPORTANT: Transom thickness and surface plane (flatness) must be controlled where the sterndrive unit mounts.

Transom Specifications	
Thickness	Between 2 - 2-1/4 in. (51 - 57 mm) for 8 in. (203 mm) to either side of the vertical centerline
Parallelism	Inner and outer surfaces must be parallel within 1/8 in. (3 mm)
Flatness	Transom surfaces in area where transom assembly will be mounted (includes vertical as well as horizontal dimensions): Inner Surface – Flat within 1/8 in. (3 mm) Outer Surface – Flat within 1/16 in. (2 mm)
Angle	10 -16 Degrees

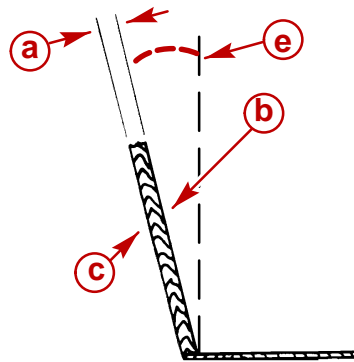

22170

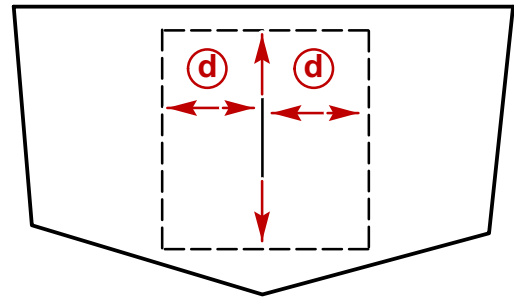

72700

- a** - Transom Thickness
- b** - Inner Surface
- c** - Outer Surface
- d** - Transom Plate Coverage
- e** - Transom Angle

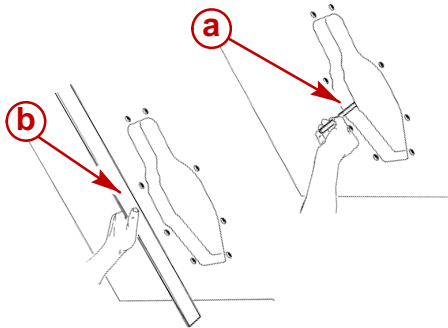

70004

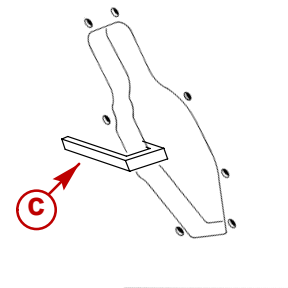

75479

- a** - Measuring Thickness
- b** - Measuring Flatness
- c** - Suitable Mandrel To Check For Uniform Transom Thickness

Engine Bed

Difference Between Starboard and Port Engine Mount	22-1/2 in. (572 mm)
Mount Adjustment Up and Down (minimum)	1/4 in. (6 mm)

NOTE: Although the engine mounts allow some adjustment, it is a good practice to ensure that the front and rear mount locations in the vessel are parallel and in the same plane. This may be checked by tying a string from the left front mount location to the right rear mount location and another from right front to left rear. The strings should touch where they cross.

Crankshaft Vertical Centerline

1. Locate and mark boat vertical centerline on transom.

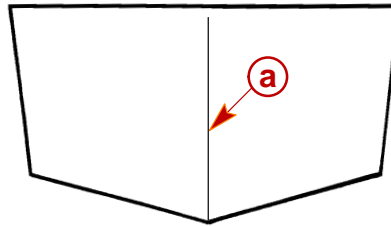

71620

a - Vertical Centerline

2. **For Dual Engines:** Locate and mark crankshaft vertical centerlines “a” on transom.

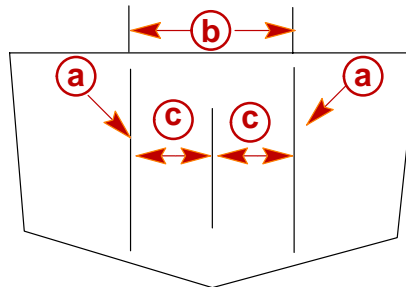

22033

- a** - Crankshaft Vertical Centerline
- b** - Minimum Distance Between Crankshaft Vertical Centerlines
- c** - Crankshaft Vertical Centerlines Must Be An Equal Distance From Boat Vertical Centerline

Minimum Distance Between Crankshaft Vertical Centerlines (Dual Side-By-Side)	
Model	in. (mm)
181 cid / 3.0L	28 (710)
262 cid / 4.3L	33 (838)
305 cid / 5.0L	
350 cid / 5.7L	

Crankshaft Horizontal Centerline (X-Dimension)

X-Dimension can be measured by the 90 degree Tool Method or by the Tape Measure Method.

90 DEGREE TOOL METHOD

1. Construct 90 degree tool.

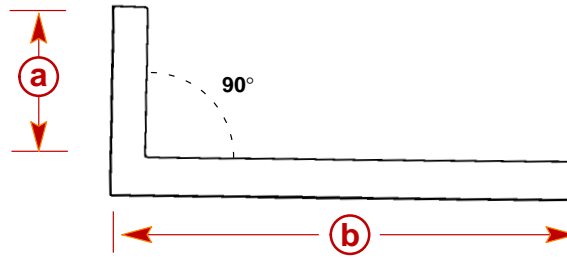

71621

- a** - 13-9/16 in. (345 mm)
- b** - Measurement: 4 ft. (1.2 m)

To Lower Drive Unit - Subtract from dimension "a."

To Raise Drive Unit - Add to dimension "a."

IMPORTANT: This dimension should only be raised or lowered after proper testing.

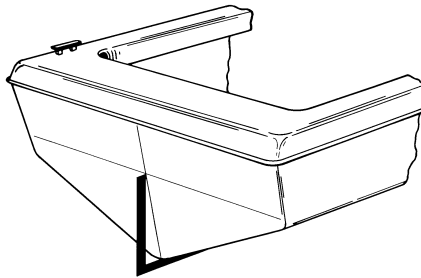

71622

Single Engine

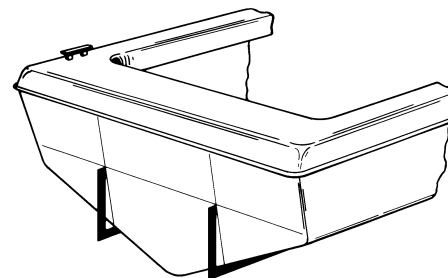

71623

Dual Engine

2. Place 90 degree tool along boat bottom at vertical centerline.
3. Locate the point at which top of tool contacts transom on vertical centerline. This is the crankshaft horizontal centerline or X-Dimension.
4. Draw a line perpendicular to vertical centerline at crankshaft horizontal centerline.

TAPE MEASURE METHOD

1. Determine X-Dimension from the following chart.

Transom Angle (degrees)	This dimension should only be raised or lowered after proper testing.
16	14-5/16 in. (364 mm)
15	14-1/4 in. (362 mm)
14	14-3/16 in. (360 mm)
13	14-1/8 in. (359 mm)
12	14-1/16 in. (357 mm)
11	14 in. (356 mm)
10	13-15/16 in. (354 mm)

2. Measure up from the boat bottom the amount shown on the chart for the appropriate transom angle.

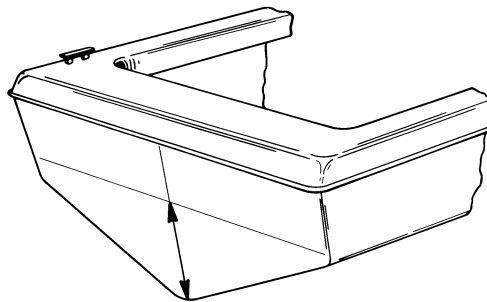

71622

Single Engine

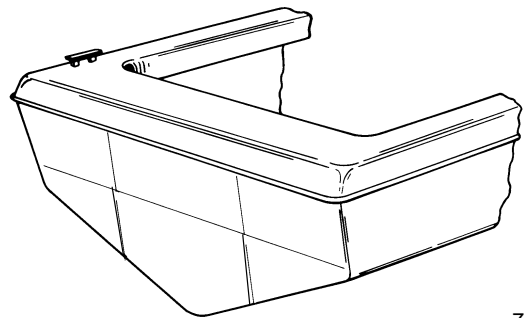

71623

Dual Engine

3. Draw a line perpendicular to vertical centerline at crankshaft horizontal centerline.

Transom Cutout

IMPORTANT: The following instructions will provide a sterndrive unit mounting location that is suitable for most boats. Best mounting location for a particular boat, however, can be determined only by testing.

1. **Below 25 mph (40 km/h):** Subtract 1/2 in. (13 mm) from X-Dimension.
2. **Heavy Duty Applications:** Subtract 1 in. (25 mm) from X-Dimension.
3. **Above 25 mph (40 km/h):** Use X-Dimension shown.
4. **Above 50 mph (80 km/h):** The X-Dimension can be increased to improve performance in some applications. However, pulling power for skiing will decrease. During testing, X-Dimension should be increased 1/2 in. (13 mm) at a time until desired performance is achieved but **in no case should it ever be increased by more than:**

Maximum Increase In X-Dimension	
Alpha	2-1/2 in. (64 mm)
Bravo One and Two	3 in. (76 mm)
Bravo Three	1 in. (25 mm)

Extreme care should be taken when raising drive unit to ensure that water supply does not become aerated. Use clear water inlet hose to monitor incoming water and monitor engine temperature gauge to ensure engine does not overheat.

In applications where cooling water to the engine is supplied by a through the hull or through the transom fitting, the sterndrive height will not cause cooling water aeration.

IMPORTANT: Damage to Mercury MerCruiser products caused by too high of an installed height will not be covered by Mercury MerCruiser warranty.

- Cut out transom using the Template or the Transom Drilling Fixture Kit (purchased separately).

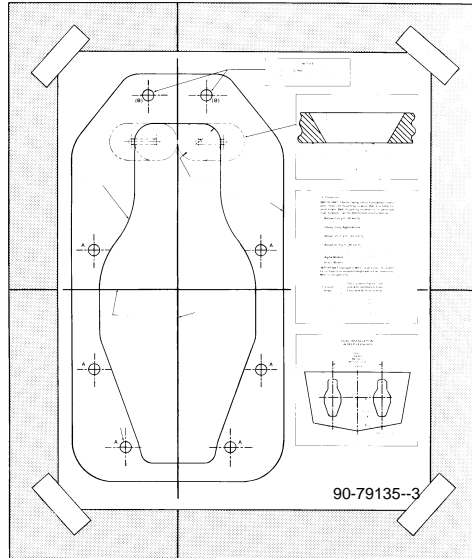

Transom Cutout Template

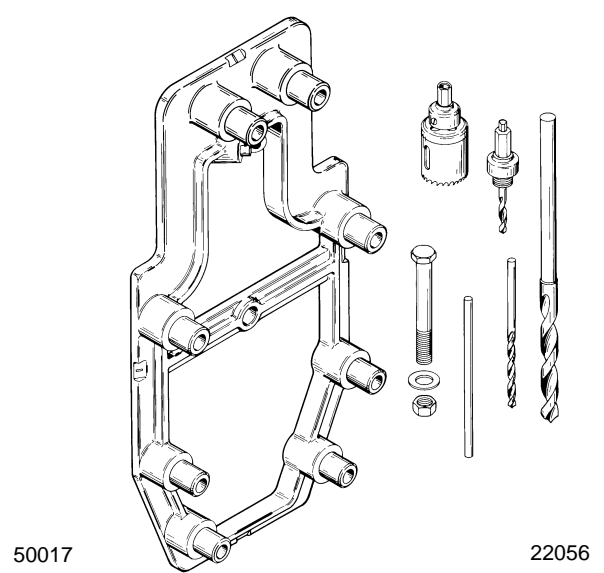

Transom Drilling Fixture Kit

- Follow instructions indicated on template or provided with drilling fixture.
- Ensure that centerlines on either the template or transom drilling fixture align with lines previously marked on transom.
- Drill 1/4 in. (6 mm) pilot holes for hole saw guide at a 60 degree angle and cut on the line when making transom cutout. If cutout is made incorrectly, drive unit steering lever may contact transom, thus limiting steering travel.
- Seal inside edge of transom cutout opening with a suitable sealant to prevent water absorption and deterioration of transom.
- Cut drain hole and install drain plug flange with appropriate fasteners.

Seawater Connections - General Information

This section covers through the hull and through the transom water inlets only. For information on sterndrive water inlet connections, refer to the appropriate section after engine installation.

IMPORTANT: Seal the inside edges of any hole made through the hull with a suitable sealant to prevent water absorption and deterioration.

Seawater Pickup

THROUGH THE HULL MOUNTED

Description	Where Used	Part Number
A Marine Caulking	Mounting Surfaces	Obtain Locally

1. Seal inside edges of 1-3/4 in. (44 mm) hole in hull using a suitable sealer.
2. Apply marine caulking (sealer) to mounting surface on seawater pickup where hull contact will occur when installed.

IMPORTANT: Seawater inlet slots must face forward - parallel with the flow of water.

3. Ensure slots in seawater pickup are facing forward (toward bow of boat) and install seawater pickup through hull.
4. Fasten pickup with four appropriate mounting screws (if so designed).

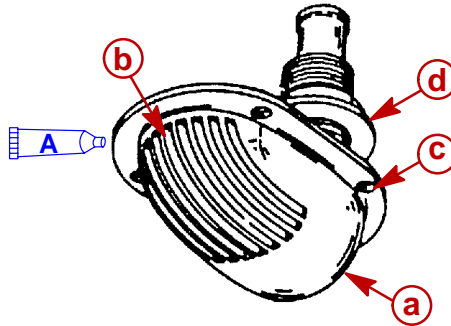

72639

- a - Seawater Pickup
- b - Seawater Inlet Slots
- c - Mounting Screw Holes (If Equipped)
- d - Nut

5. Apply marine caulking as needed inside boat. Apply sealant to threads of nut and install on pickup on inside of boat and torque nut.

Description	Where Used	Part Number
Loctite 271	Seawater Inlet Nut	92-809820

Description	Nm	lb-in.	lb-ft
Nut	42		35

NOTE: If pickup being installed does not have mounting screws on underside where mounted to hull, be certain, after nut is torqued, that slots are still facing forward.

TRANSOM MOUNTED

1. Seal the inside edges of the 1-1/2 in. (38 mm) hole hose fitting.
2. Ensure that the hose fitting and plastic plug are in place and threads have been sealed prior to tightening each securely.

Description	Where Used	Part Number
A Loctite 592 PST	Hose Fitting Threads	Obtain Locally
	Plastic Plug Threads	
B Silicone Sealant Or Equivalent	Screw Shaft	

NOTE: Use a sharp knife or wood chisel to remove excess plastic plug material so that plug is flush with pickup casting.

3. Position one flat washer and one rubber O-ring on each 5/16 in. x 4 in. (102 mm) long, round head screw. Coat each screw shaft with sealant.
4. Place new gasket on pickup housing and hold pickup in place on transom. Install four round head screws (with washers and O-rings in place) into pickup mounting holes and through drilled 21/64 in. (8 mm) holes in transom.

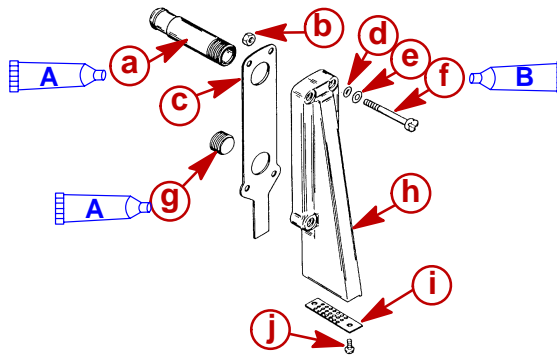

72640

- a - Hose Fitting
- b - Nut (4)
- c - Gasket
- d - O-ring (4)
- e - Washer (4)
- f - Screw (4)
- g - Plastic Pug
- h - Pickup
- i - Screen
- j - Screw (2)

NOTE: Some installations may have 7/32 in. (5 mm) holes drilled in transom using four 5/16 in. diameter stainless steel lag bolts in place of round head screws. In any case, flat washers and O-rings are required as outlined.

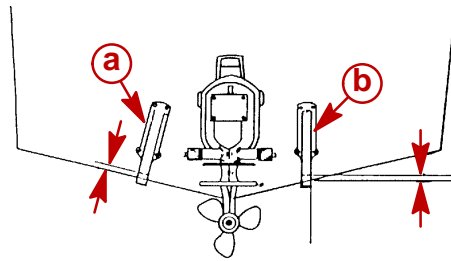

72641

Water Pickup Installed on Transom

- a** - Diagonal Mount - Leading Edge Of Pickup 1/8 in. (3.2 mm) From Boat Bottom.
- b** - Vertical Mount - Corner Of Leading Edge Of Pickup 1/8 in. (3.2 mm) From Boat Bottom

5. Secure water pickup from inside with locknuts and washers (unless using lag bolts).
6. Tighten fasteners securely.

Preliminary Connections

Power Trim Pump

1. Select an appropriate mounting location for the trim pump that:
 - Is within length limits of black and gray hydraulic hoses coming from gimbal housing assembly.
 - Is close to the battery so that trim pump battery leads can be connected.
 - Allows easy access to trim pump oil fill and vent locations.
 - Is in an area where pump will not be exposed to water.
 - Prevents the power steering booster cylinder from coming in contact with the trim pump when the steering wheel is turned in either direction (right or left).

NOTE: Template 90-863152 provides mounting hole location for floor or transom mounting.

2. Remove the cap plug.
3. Mount the pump in the desired location.

Fuel Inlet Fitting

IMPORTANT: The following information is provided to ensure proper installation of brass fittings or plugs installed into fuel pump or fuel filter base:

- Use #592 Loctite Pipe Sealant with Teflon on threads of fuel inlet fittings or plugs. **DO NOT USE TEFLON TAPE.**
- Fuel inlet fittings or plugs should first be threaded into fuel pump or fuel filter base until finger tight.
- Fuel inlet fittings or plugs should then be tightened an additional 1-3/4 to 2-1/4 turns using a wrench. **DO NOT OVERTIGHTEN.**
- To prevent over-tightening when installing a fuel line, the brass fittings should be held with a suitable wrench as fuel inlet fittings are tightened securely.

⚠ WARNING

Boating standards (NMMA, ABYC and others) and Coast Guard regulations must be adhered to when installing fuel delivery system.

⚠ WARNING

Avoid gasoline fire or explosion. Improper installation of brass fittings or plugs into fuel pump or fuel filter base can crack casting and/or cause a fuel leak.

1. Remove plastic plug from fuel inlet hole.
2. Apply sealant to threads of fuel inlet fitting. **DO NOT USE TEFLON TAPE.**
3. Install fuel inlet fitting. To prevent cracking the casting or causing fuel leaks, turn fuel inlet fitting in by hand until finger tight, then tighten connector to 1-3/4 to 2-1/4 turns with wrench. **DO NOT** overtighten.

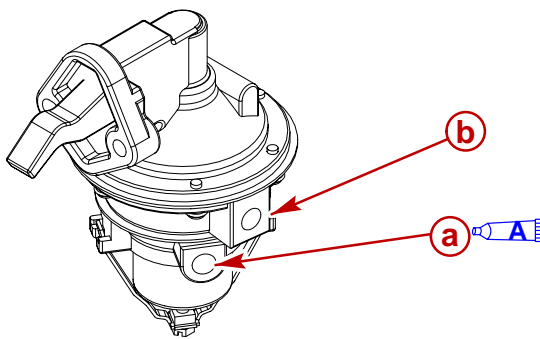

78165

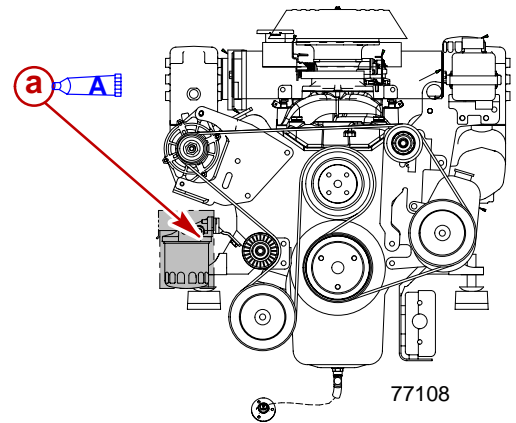

77108

3.0L Model

- a** - Fuel Inlet Hose Connects Here
- b** - Fuel Outlet

Typical V6 And V8 Models

Description	Where Used	Part Number
A Loctite 592	Fuel Inlet Fitting	Obtain Locally

SPECIAL INFORMATION ABOUT ELECTRIC FUEL PUMPS

⚠ CAUTION

The electric fuel pump and factory installed water separating fuel filter have been carefully designed to function properly together. Do not install additional fuel filters and/or water separating fuel filters between fuel tank and engine.

The installation of additional filters may cause:

- Fuel Vapor Locking
- Difficult Warm-Starting
- Piston Detonation Due to Lean Fuel Mixture
- Poor Driveability

Transom Connections

Installing Gimbal Housing

1. Carefully remove transom assembly from shipping carton.
2. Remove and read all tags attached to transom assembly.

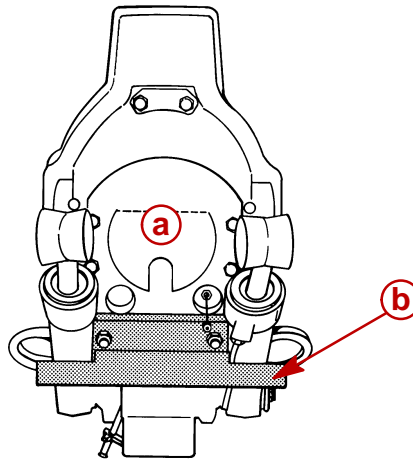

22027

- a** - Dust Cover
- b** - Shipping Hardware

3. Remove the shipping hardware.
4. Remove the dust cover if boat will be shipped with drive installed.
5. Retain the serial number envelope.

Installing Inner Transom Plate

1. Insert wires, hoses and shift cable through appropriate openings in inner transom plate.
2. Position gimbal housing on transom and hold in place.

IMPORTANT: Tighten the transom assembly fasteners using an X-pattern torque sequence, starting from the middle fasteners. Tighten in small increments and go around the pattern several times until the proper torque is achieved.

3. Secure transom assembly with hardware as shown. Torque the hardware.

Description	Nm	lb-in.	lb-ft
Transom Assembly Hardware	31		23

4. Attach continuity wires.

IMPORTANT: Steering lever continuity circuit wire must be positioned as shown to avoid stressing wire when steering lever moves.

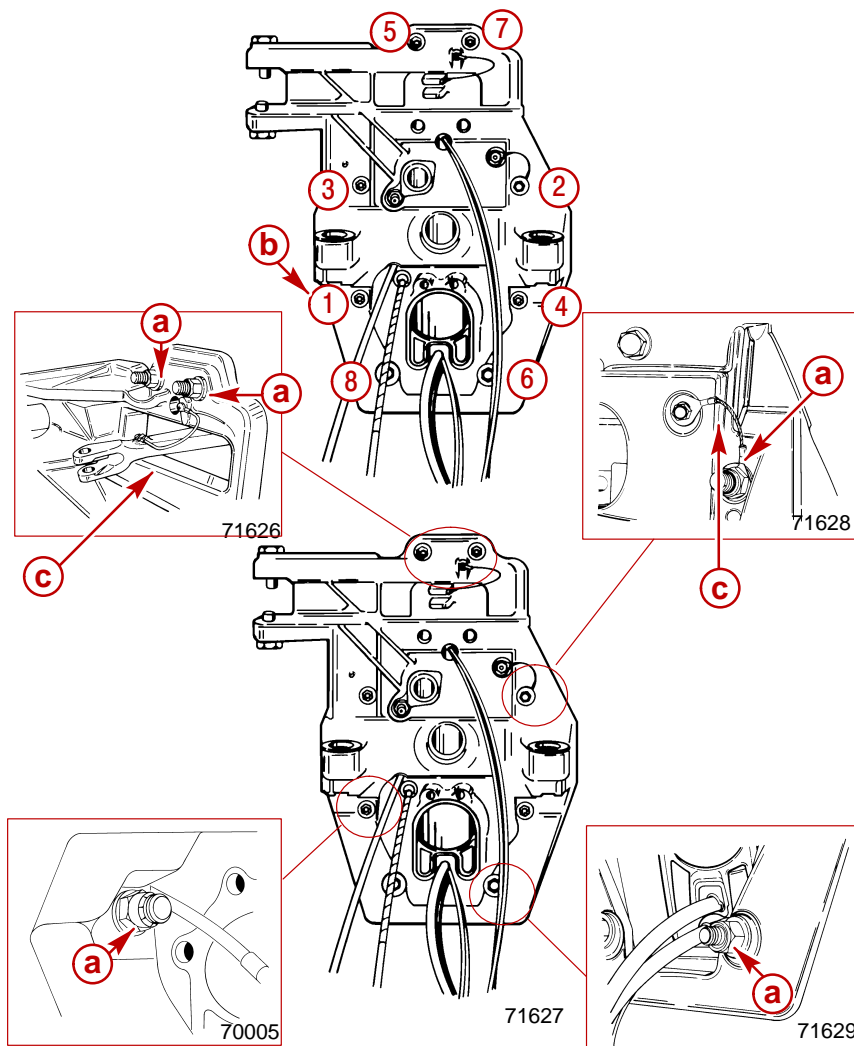

- a** - Locknuts And Flat Washers (8)
- b** - Torque Sequence
- c** - Continuity Wire

5. Install the water inlet fitting and j-clip for the gear lube and the speedometer hose.

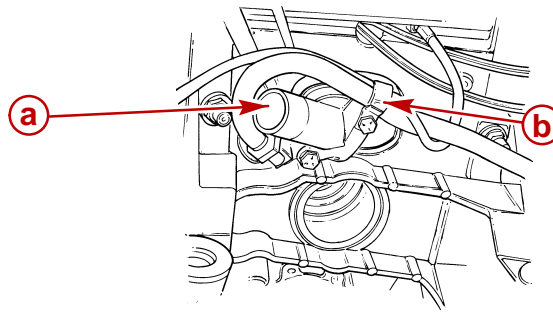

77916

- a - Water Inlet Fitting
- b - J-clip

6. Torque J-clip fasteners.

Description	Nm	lb-in.	lb-ft
J-Clip Fasteners	5	45	

Connecting Speedometer Pickup

⚠ CAUTION

Excess water in bilge can damage engine or cause boat to sink. Do not remove plug from speedometer pickup tube fitting unless connection is to be utilized.

The connection for the speedometer pickup can be accessed through a hole and fitting in the inner transom plate.

1. Remove plug from speedometer pickup tube fitting.

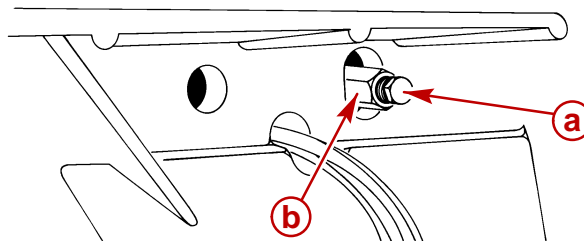

70037

- a - Plug
- b - Inner Transom Plate Fitting

2. Apply sealant to threads of barb fitting. Install and torque the barb fitting.

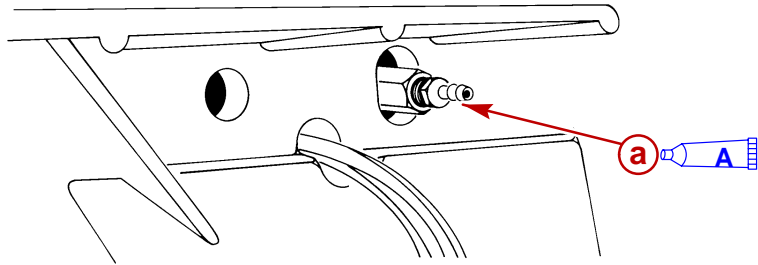

70015

a - Barb Fitting

Description	Where Used	Part Number
A Loctite 592	Speedometer Barb Fitting	Obtain Locally

Description	Nm	lb-in.	lb-ft
Barb Fitting	1.5	13	

3. Connect a 5/32 in. (4 mm) speedometer hose (not provided) hose from speedometer to barb fitting. Secure hose with cable tie.
4. Secure the hose to the transom with the hose clip and screw that are provided in the parts bag.

NOTE: The hose must not come into contact with the steering system components or the engine coupler and drive shaft.

Fluid Connections

1. Connect the gear lube monitor hose to the quick release 90 degree fitting.

⚠ CAUTION
Avoid sterndrive unit damage. Quick release button on gear lube monitor 90 degree hose fitting may not lock on gimbal housing if touching or depressed by water inlet fitting or block-off plate, if equipped. Failure to do so could result in a loose 90 degree fitting causing a loss of gear lube and damage to drive unit.

2. Connect 90 degree fitting to the gimbal housing.

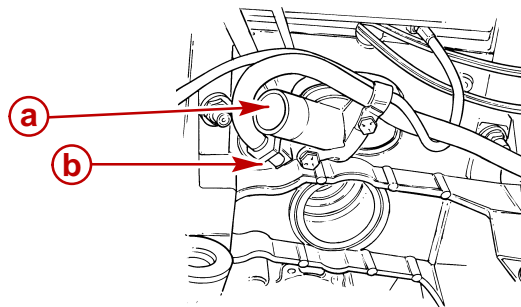

77916

a - Water Inlet Fitting
b - 90 Degree Fitting

NOTE: The quick release button on hose fitting must be positioned away from water inlet fitting, or block-off plate if equipped. Release button must not contact water fitting or block-off plate, if equipped.

NOTE: The hose must not come into contact with the steering system components or the engine coupler and drive shaft.

3. Select a mounting location for coolant recovery bottle and mounting bracket that meets all of the following:
 - Within limits of clear plastic tubing.
 - Level with or above the heat exchanger fill neck.
 - Accessible for observing coolant level and filling.
4. Mount coolant recovery bottle and mounting bracket in desired location using two 3/4 in. (19 mm) long screws and flat washers.
5. Route plastic tubing to recovery bottle. Ensure that tubing is positioned away from any moving parts. Cut plastic tubing as required and connect to bottom connection on recovery bottle and secure with tubing clamp provided.
6. Fasten plastic tubing to boat, as necessary, with 2 hose clips and 1/2 in. (13 mm) long screws (provided).

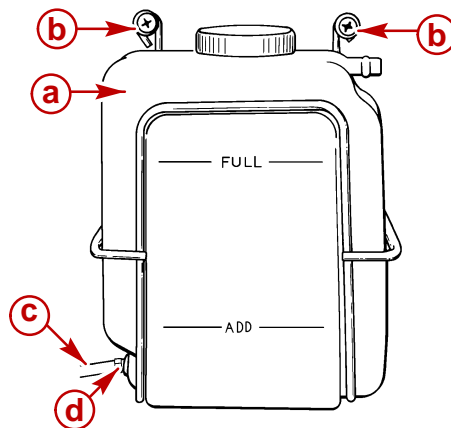

71712

- a** - Recovery Bottle And Mounting Bracket
- b** - Screws And Flat Washers
- c** - Plastic Tubing
- d** - Tubing Clamp

Installing Steering System

HYDRAULIC (HELM) STEERING

If your power package is equipped with Compact Hydraulic Steering, refer to the *Compact Hydraulic Steering Installation Instructions* in the box with the compact hydraulic steering components. Complete the installation of the hydraulic steering system before proceeding to Transom Preparation.

POWER STEERING

NOTE: For dual installations, power steering unit can be mounted on port or starboard transom assembly. Measure exact distance between power package centerlines. Select a tie bar from Mercury Precision Parts / Quicksilver Accessory Guide. Refer to tie bar installation instructions before proceeding.

1. Inspect the bushings for debris. Lubricate the bushings.

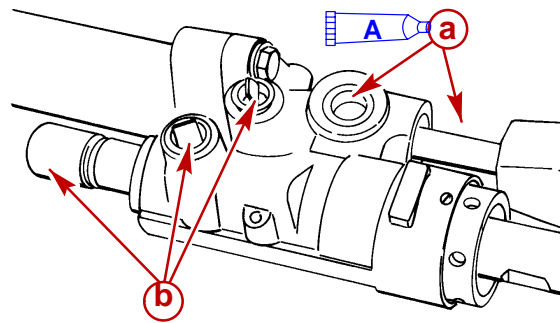

73898

- a - Bushings
- b - Shipping Hardware

Description	Where Used	Part Number
A Special Lubricant 101	Bushings	92-13872A1

2. Remove shipping hardware.
3. Remove the cotter pins.
4. Loosen the upper and lower pivot bolts and ensure that the threads are well lubricated.. Add lubricant as necessary.

Description	Where Used	Part Number
Special Lubricant 101	Pivot Bolts	92-13872A1

5. Install steering assembly as follows:
 - a. Position steering assembly so that pivot bolts will enter bushings in pivot block or power steering control valve.
 - b. Install upper and lower pivot bolts along with tab washers. Ensure that tab washer tangs straddle the ridge on inner transom plate.
 - c. Turn pivot bolts all the way in by hand to ensure proper alignment.
 - d. Ensure steering assembly pivots freely.
6. Torque pivot bolts. Bend tab washer tangs against corresponding flats on bolt heads.

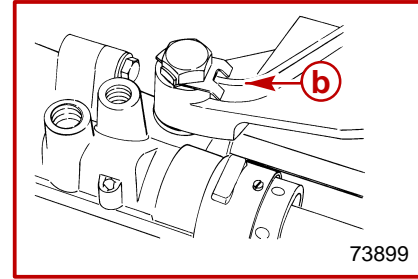
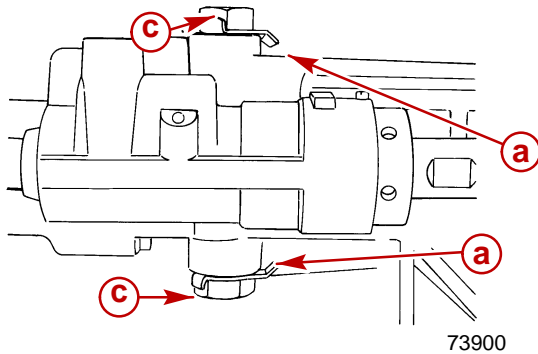

- a** - Tab Washers
- b** - Ridge
- c** - Pivot Bolts

Description	Nm	lb-in.	lb-ft
Pivot Bolts	34		25

NOTE: It may be necessary to tighten further to align flats on pivot bolt with tangs on tab washer.

⚠ CAUTION

MOVING THE CONTROL VALVE RAM with the hoses disconnected will expel fluid from the control valve ports. Wear eye protection.

- The control valve ram may be stiff and difficult to move when you attempt to pull it out or push it in for installation. Move the assembly in the directions shown below.

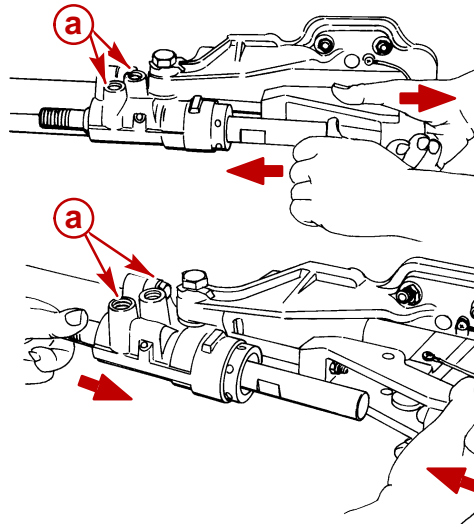

74145

74144

a - Control Valve Ports

- Connect clevis to steering lever. Lubricate clevis pin. Be sure to spread both ends of cotter pin.

NOTE: Make sure to insert clevis pin from the top to ensure that cotter pin hole is as shown in the diagram.

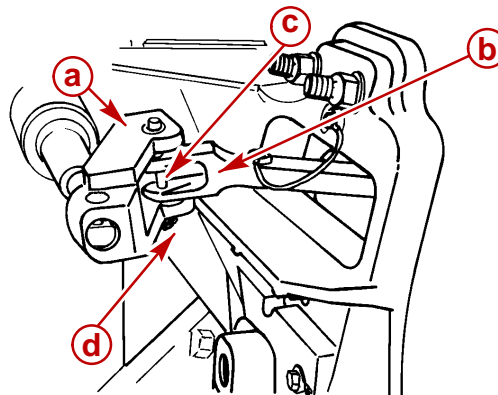

71904

- a** - Clevis
- b** - Steering Lever
- c** - Clevis Pin
- d** - Cotter Pin

Description	Where Used	Part Number
A Special Lubricant 101	Clevis Pin	92-13872A1

IMPORTANT: Quicksilver Ride Guide steering cable has a self-locking coupler nut and does not require an external locking sleeve or locking plate.

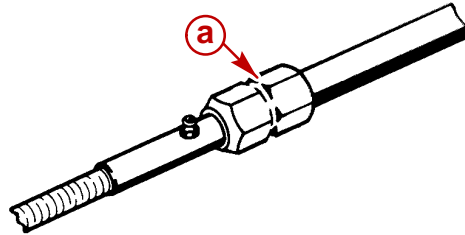

22060

a - Self-Locking Coupler Nut

CAUTION

Steering cable outer casing must be free to move back and forth for steering system to function properly. Do not fasten any items to steering cable.

9. Coat steering cable end with a liberal amount of lubricant.
10. Install steering cable and secure with hardware.

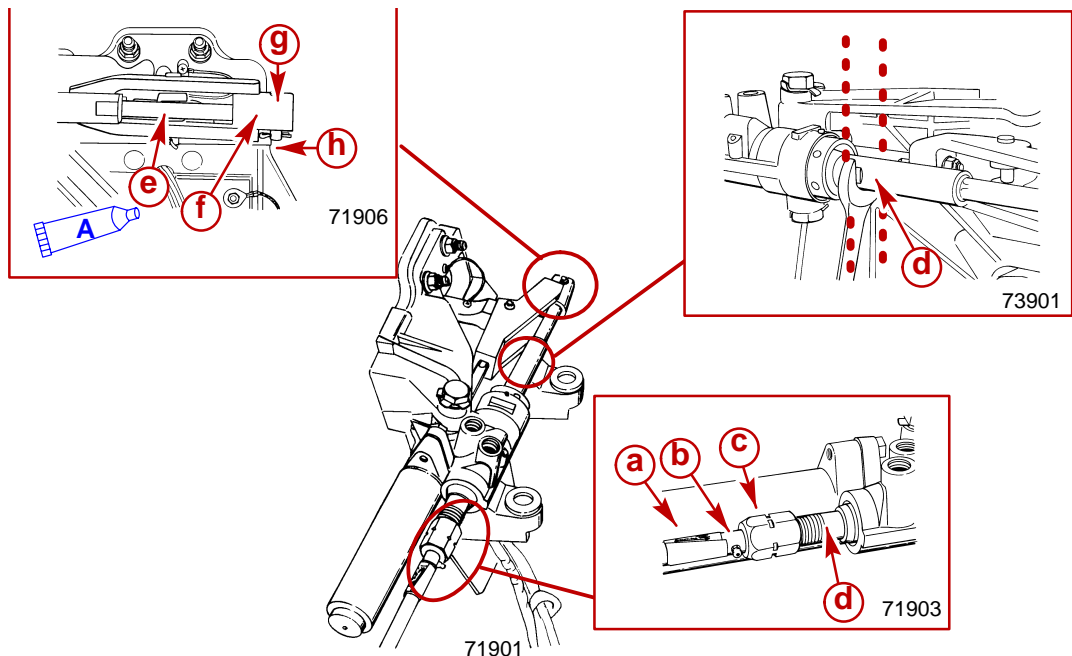

- a** - Steering Cable
- b** - Grease Fitting
- c** - Cable Coupler Nut
- d** - Cable Guide Tube
- e** - Steering Cable End
- f** - Clevis
- g** - Clevis Pin
- h** - Cotter Pin

Description	Where Used	Part Number
A Special Lubricant 101	Steering Cable End	92-13872A1

IMPORTANT: Slight feedback in the steering system could be encountered if the cable guide tube flat surfaces are not positioned vertically.

11. Using a suitable wrench hold the flat surfaces on the cable guide tube in the vertical position. Torque coupler nut. **Be certain the flat surfaces are still aligned vertically after torque is applied to coupler nut.**

Description	Nm	lb-in.	lb-ft
Coupler Nut	47		35

⚠ CAUTION

Steering cable outer casing must be free to move back and forth for steering system to function properly. Do not fasten any items to steering cable.

MANUAL STEERING

1. Inspect bushings for debris. Lubricate bushings with Special Lubricant 101.

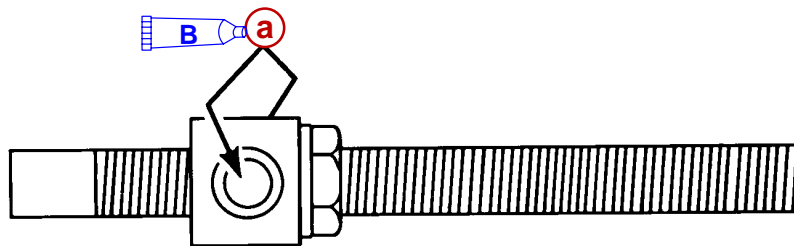

22946

Manual Steering

- a** - Bushings
- b** - Special Lubricant 101

2. Remove shipping hardware.
3. Remove upper and lower pivot bolts and ensure threads are well lubricated with Special Lubricant 101.

NOTICE to INSTALLER

Refer to "Installation Requirements - Steering Helm and Cable" for steering cable selection and coupler nut locking requirements.

4. Install steering assembly as follows:
 - a. Position steering assembly so that pivot bolts will enter bushings in pivot block or power steering control valve.
 - b. Install upper and lower pivot bolts along with tab washers. Ensure that tab washer tangs straddle the ridge on inner transom plate.
 - c. Turn pivot bolts all the way in by hand to ensure proper alignment.
 - d. Ensure steering assembly pivots freely.
5. Torque pivot bolts to 25 lb-ft (34 Nm). Bend washer tabs against corresponding flats on bolt heads.

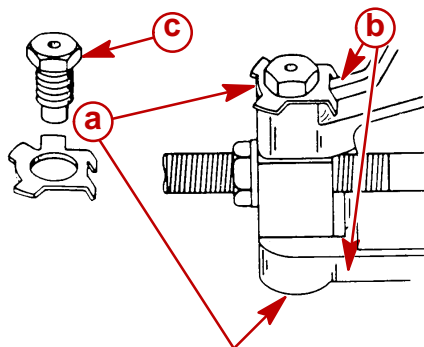

22033

Manual Steering

- a** - Tab Washers
- b** - Ridge
- c** - Pivot Bolts

NOTE: It may be necessary to tighten further to align flats on pivot bolt with tabs on tab washer.

⚠ CAUTION

MOVING THE CONTROL VALVE RAM with the hoses disconnected will expel fluid from the ports. Wear eye protection.

6. The cylinder ram may be stiff and difficult to move when you attempt to pull it out or push it in for installation. First move the spool assembly in the direction(s) shown below.

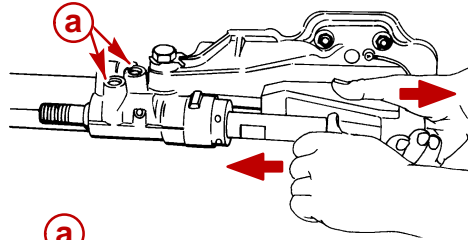

74145

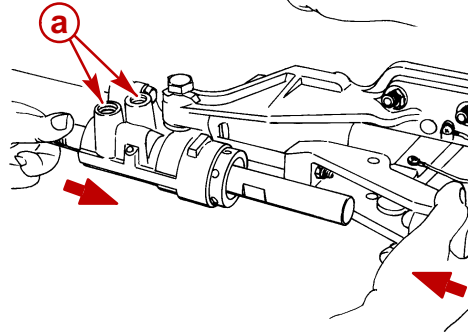

74144

a - Control Valve Ports

IMPORTANT: Newer style Quicksilver Ride Guide steering cable has a self-locking coupler nut and does not require an external locking sleeve or locking plate.

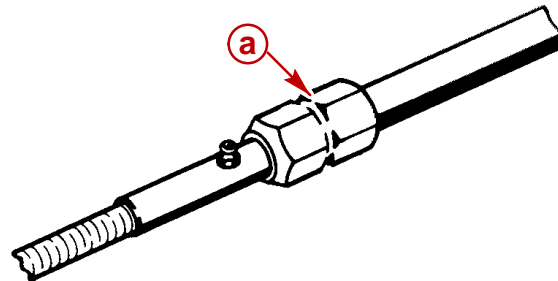

22060

a - Self-Locking Coupler Nut

⚠ CAUTION

Steering cable outer casing must be free to move back and forth for steering system to function properly. Do not fasten any items to steering cable.

7. Connect steering cable as follows:
 - a. Remove shipping cap from both ends of steering cable guide tube or control valve spool.
 - b. Coat steering cable end with a liberal amount of Special Lubricant 101.
 - c. Install steering cable and secure with hardware as shown on following pages.

NOTICE to INSTALLER

Refer to "Installation Requirements - Steering Helm and Cable" for steering cable selection and coupler nut locking requirements.

IMPORTANT: Slight feedback in the steering system could be encountered if the cable guide tube flat surfaces are not positioned vertically.

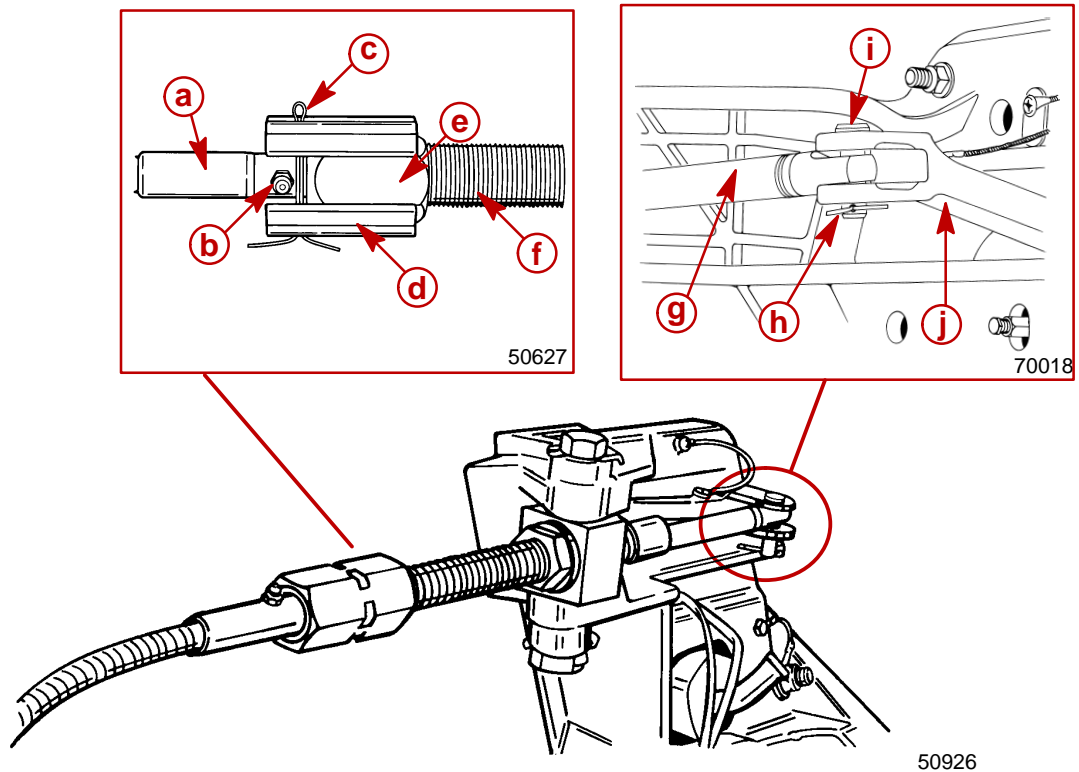

- a** - Steering Cable
- b** - Grease Fitting
- c** - Cotter Pin
- d** - Locking Sleeve (If Required - Must Be Ordered Separately)
- e** - Cable Coupler Nut
- f** - Cable Guide Tube
- g** - Steering Cable End
- h** - Cotter Pin
- i** - Clevis Pin
- j** - Steering Lever

STEERING HELM AND CABLE

Transom assembly is shipped with the steering cable guide tube preset for cables with end dimensions that comply with ABYC standards as outlined in the NMMA certification handbook. The steering cable coupler nut must also have a means of locking it to the guide tube, as specified in ABYC requirements.

WARNING

Failure to use a steering cable locking device could cause loss of steering, which could cause damage to the boat and/or injury.

NOTE: All current production Quicksilver RideGuide steering cables have a self-locking coupler nut and do not require an external locking device. (Other cable manufacturers also make cables with self-locking coupler nut.)

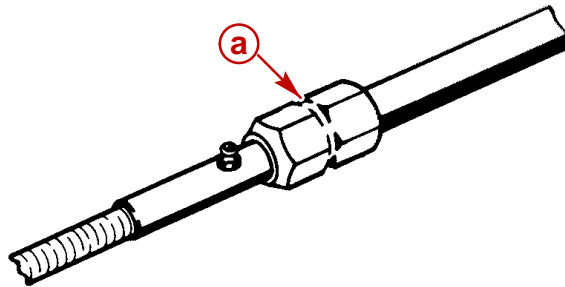

22060

a - Quicksilver RideGuide Steering Cable Self-Locking Coupler Nut (Identified By Groove)

IMPORTANT: If using a steering cable that does not have a self-locking coupler nut, an external locking device such as a locking sleeve must be used.

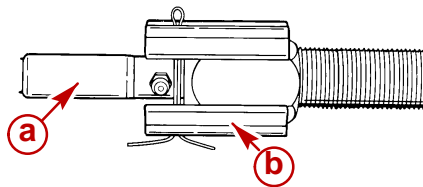

Example Of External Locking Device

a - Steering Cable
b - Locking Sleeve

CAUTION

If steering cable with improper dimensions is installed, severe damage to transom assembly and/or steering system may result.

1. Steering cable must be the correct length, particularly when installed in larger boats.
2. Avoid sharp bends, kinks or loops in cable.
3. Fully extended steering cable end dimension must be as shown.

STEERING CABLE SPECIFICATIONS

IMPORTANT: Power steering pump lugging (squealing) in a hard right turn (against lock) may mean a steering cable has been installed that does not have the correct dimensions.

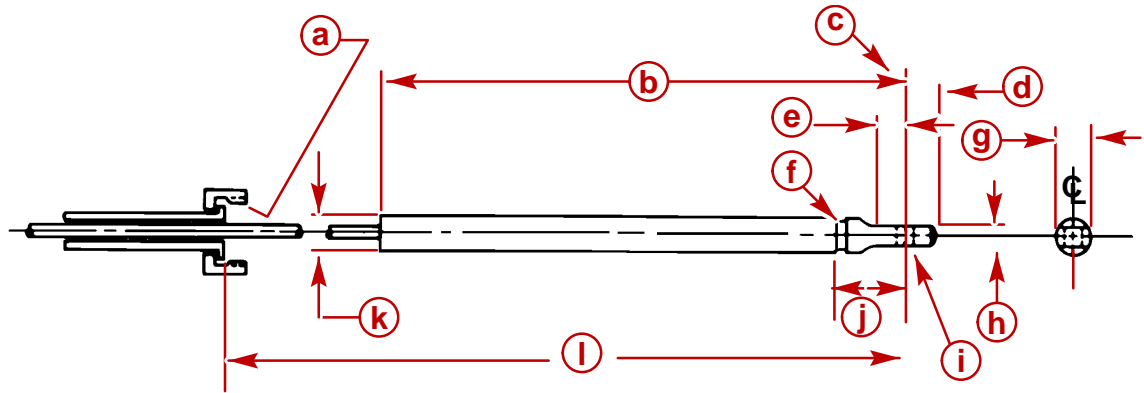

21435

- a** - Coupler Nut - 7/8 - 14 UNF - 28 Thread
- b** - 11-3/4 in. (298 mm) Minimum
- c** - Interface Point
- d** - 1/2 in. (12.7 mm) Maximum
- e** - 27/64 in. (10.7 mm) Minimum Flat
- f** - 7/64 in. (3.1 mm) Minimum Radius
- g** - 5/8 in. (15.9 mm) Maximum Diameter End Fitting
- h** - 3/8 in. (9.5 mm)
- i** - 3/8 in. (9.8 mm) Diameter Through Hole (Chamfered Each Side)
- j** - 1-3/8 in. (34.9 mm) Max
- k** - 5/8 in. (15.9 mm) Diameter Tube
- l** - Cable Travel: Mid-Travel Position - 16-7/8 in. (429 mm)
 Total Travel To Be 8 in. (203 mm) Minimum to 9 in. (228 mm) Maximum
 Travel Each Side of Mid-Travel Position - 4 in. (102 mm) Minimum to
 4-1/2 in. (114 mm) Maximum

Transom Preparation

IMPORTANT: Exhaust pipe and gimbal housing mating surfaces must be clean and free of nicks and scratches and O-ring must be properly seated in groove or water and exhaust may leak into boat.

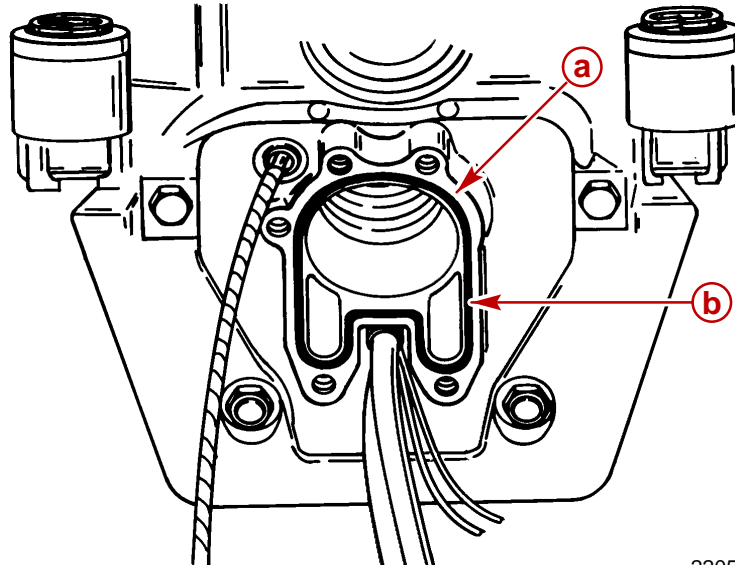

22059

- a** - Gimbal Housing Mating Surface
- b** - O-ring

1. Ensure mating surfaces are clean and o-ring is properly seated.
2. Loosen hose clamps and remove exhaust pipe and bellows from engine.

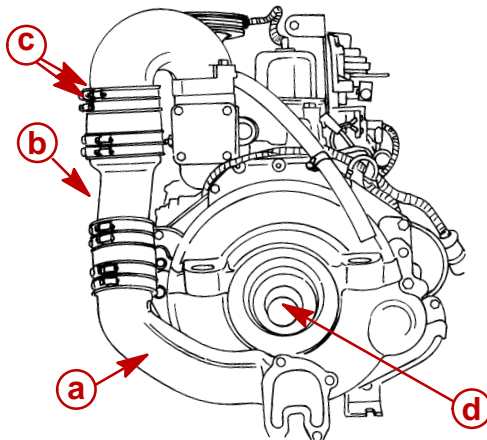

75819

3.0L Model

- a** - Exhaust Pipe
- b** - Bellows
- c** - Clamps
- d** - Shipping Plug

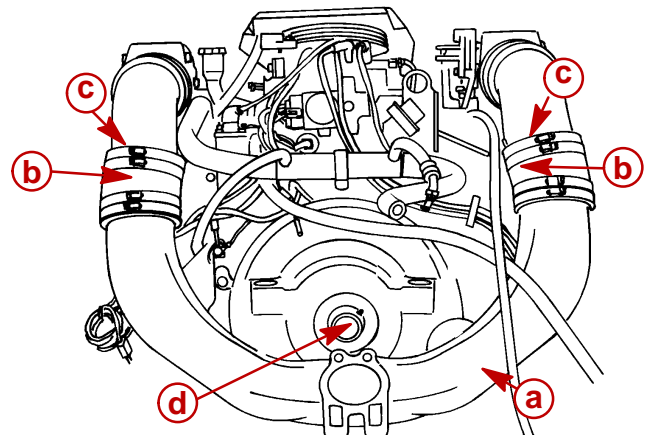

74768

V6 and V8 Models

3. **Through the Prop Exhaust Models:** Install exhaust pipe assembly as shown, using four bolts and lockwashers. Torque bolts.

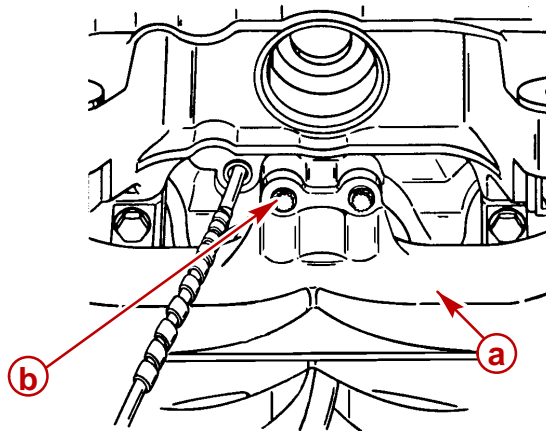

50684

- a** - Exhaust Pipe
- b** - Bolts And Lockwashers (4)

Description	Nm	lb-in.	lb-ft
Bolts	31		23

4. **Through the Transom Exhaust Models:** Install block-off plate as shown, using four bolts and lockwashers. Torque bolts.

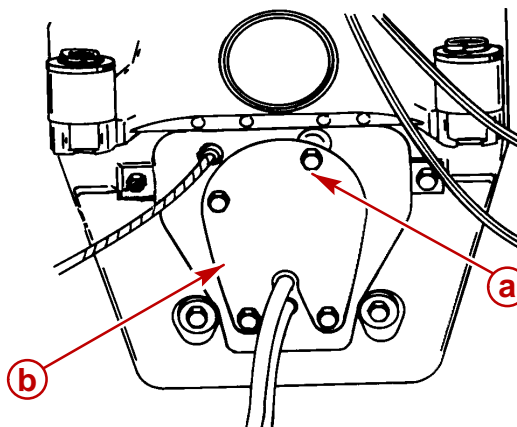

22057

- a** - Bolts And Lockwashers (4)
- b** - Block-Off Plate

Description	Nm	lb-in.	lb-ft
Bolts	31		23

NOTE: Through the Transom exhaust fittings can be installed at this time.

5. Position rear engine mount attaching hardware on inner transom plate mounts as shown.

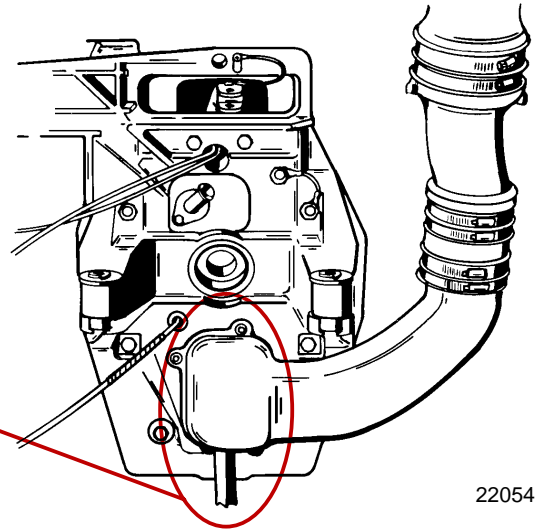
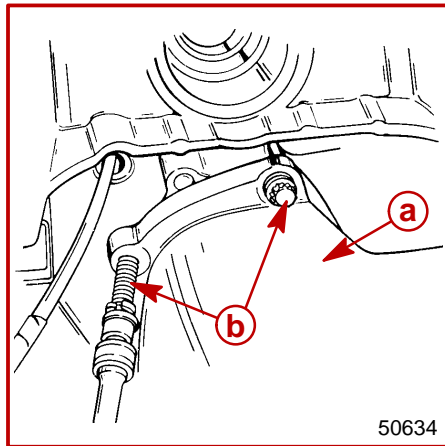

3.0L Models

- a** - Exhaust Pipe
- b** - Bolts and Lockwashers (4)

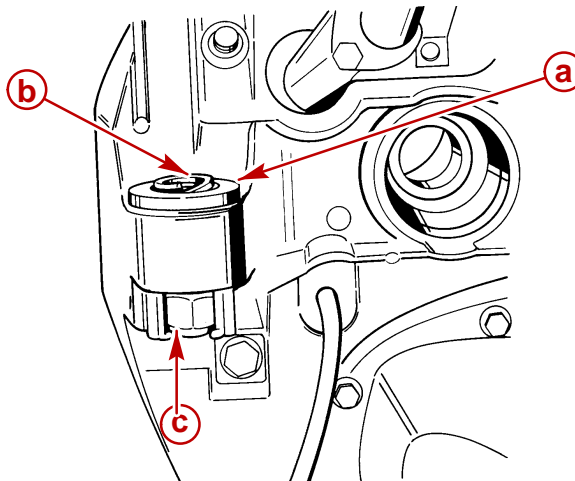

- a** - Fiber Washers
- b** - Double-Wound Lockwashers
- c** - Locknuts

BRAVO MODELS

IMPORTANT: When installing through the transom exhaust, it is recommended that the exhaust bellows on the transom assembly be removed. This is necessary to avoid creating a vacuum at the exhaust outlet in the propeller at higher boat speeds. This vacuum could degrade propeller performance on some boats.

1. If required, remove and discard clamps and bellows from gimbal housing.

IMPORTANT: When installing through the propeller exhaust:

- With Bravo One and Bravo Two Sterndrives an exhaust tube **MAY BE INSTALLED** for a slight increase in performance.
- With most Bravo Three Sterndrive Models an exhaust tube **MAY BE INSTALLED** for a slight increase in performance.
- With a Silent Choice Exhaust System the exhaust bellows must be removed and an exhaust tube **MUST BE INSTALLED**.
- With any application, installation of an exhaust tube will increase exhaust noise.

NOTE: Exhaust tube parts are provided with a Bravo Three Sterndrive. They are located in the sterndrive unit box.

2. If required, install exhaust tube on gimbal housing as follows:
 - a. Remove and discard clamps and exhaust bellows.

⚠ CAUTION
Exhaust tube clamp may corrode if grounding clip is not installed.

- b. Install grounding clip on tube.

NOTE: Bellows adhesive is not used when installing an exhaust tube.

- c. Position tube so that “SIDE” markings on tube are facing toward the right and left sides.
 - d. Install and torque the clamp.

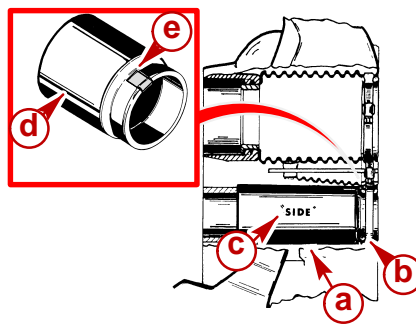

22184

- a** - Exhaust Tube
- b** - Clamp
- c** - SIDE Marking
- d** - Exhaust Tube
- e** - Grounding Clip

Description	Nm	lb-in.	lb-ft
Clamp	4	35	

Driveshaft Extension Models

If your power package is equipped with a driveshaft extension, refer to the Driveshaft Extension Installation Instructions included with your engine package.

Engine Preparation

1. Remove and read all tags attached to engine.
2. Remove the plug from the engine coupler.
3. Remove all hardware that secures engine to shipping container.
4. Connect battery cables to engine. Be sure to observe the following:
 - a. Make sure that grounding stud and starter solenoid terminal are free of paint or any other material that could cause a poor electrical connection.
 - b. After battery cables are connected, apply a thin coat of sealant to the terminals.

Description	Where Used	Part Number
A Liquid Neoprene	Battery Terminals	92-25711-2

- c. Be sure to slide rubber boot over positive (+) terminal after making connection.
5. Drape battery cables over top of engine to prevent interference during installation.

IMPORTANT: There is a fuse located at the starter solenoid. DO NOT remove this fuse. The positive battery cable must be connected to the same stud as the fuse.

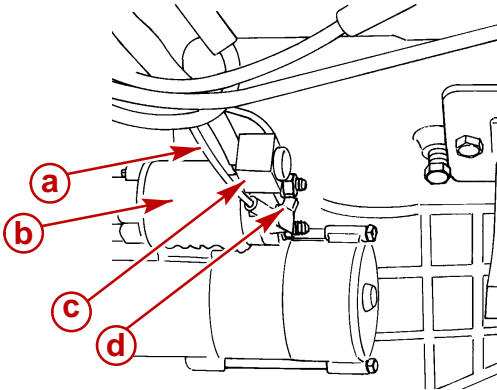

74907

- a** - Positive (+) Battery Cable
- b** - Starter Solenoid
- c** - 90 Amp Fuse - DO NOT Remove
- d** - Rubber Boot Location

6. Remove shipping plug from coupler and lubricate splines.

Description	Where Used	Part Number
A Engine Coupler Spline Grease	Coupler Splines	92-816391A4

7. Install quick oil drain hose plug in oil drain hose.
8. Install the fuel inlet fitting.

Engine Installation

NOTE: An engine mount drilling fixture (91-806794A1) can be used to align and adjust engine mounts. Refer to instructions with fixture for proper use.

1. Remove the engine cover.
2. Attach a suitable sling to lifting eyes on engine and adjust so that engine is level when suspended.

⚠ CAUTION

Center lifting eye on top of thermostat housing is used for engine alignment only. Do not use to lift entire engine.

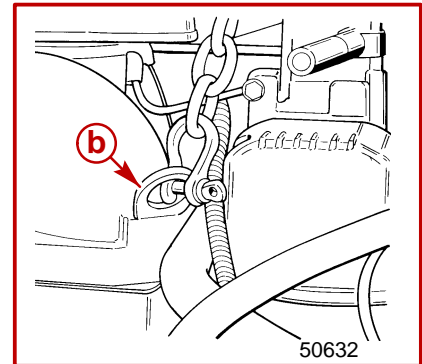
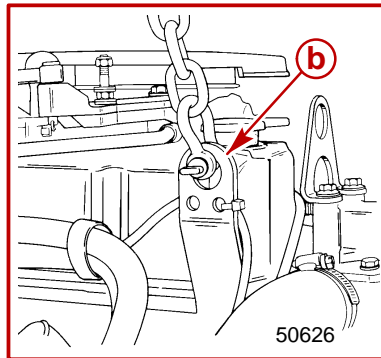
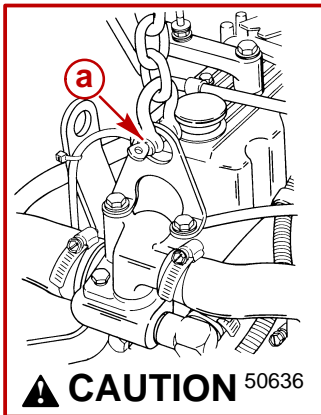

3.0L Models

- a** - Center Lifting Eye
- b** - Engine Lifting Eyes

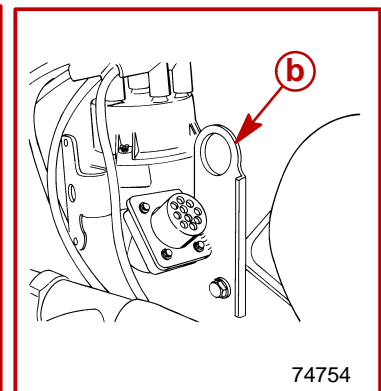
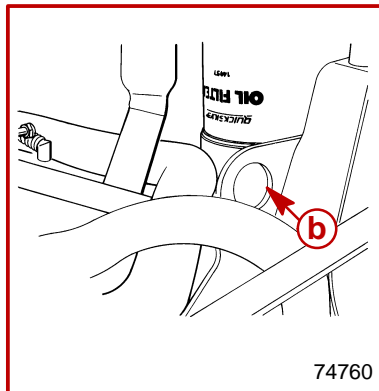
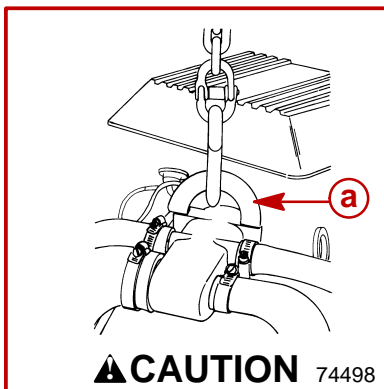

V6 and V8 Models

- a** - Center Lifting Eye
- b** - Engine Lifting Eyes

3. Loosen the engine mount adjustment nut.
4. Lift engine into position in boat using an overhead hoist.

5. Line up the intermediate elbows with the exhaust tubes.
6. Spray lubricant into the exhaust tubes to assist with intermediate elbow installation into exhaust tubes.

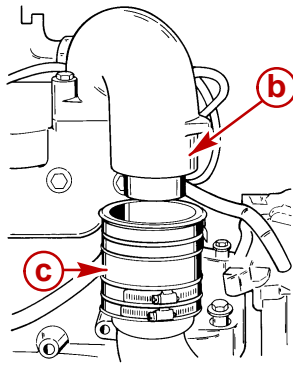

50635

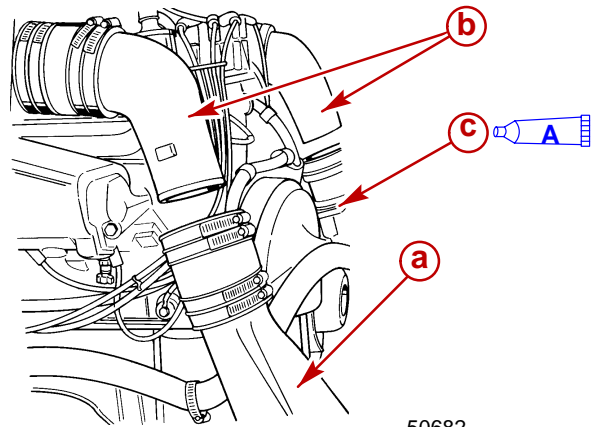

50682

3.0L Models

- a** - Bullhorn
- b** - Intermediate Elbow
- c** - Exhaust Tube

Typical V6 And V8 Models

Description	Where Used	Part Number
A Power Tune	Exhaust Tubes	92-802878-57

7. If equipped with quick drain oil:
 - a. Push end of oil drain hose out of boat hull through flange.
 - b. Pull oil drain hose out until it is 6 in. (152 mm) from the propeller.
 - c. Move alignment clip on the oil drain hose and squeeze to position it on the hose just inside of the boat hull against the flange.
 - d. Connect bilge drain plug to oil drain hose plug using clip.

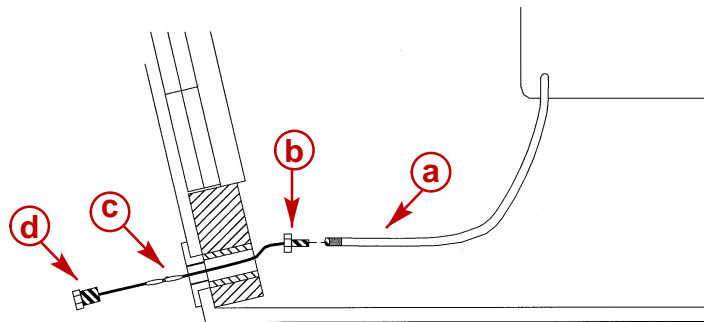

78002

- a** - Oil Drain Hose
- b** - Alignment Clip
- c** - Clip
- d** - Bilge Drain Plug

- e. Push oil drain hose through flange into boat hull.
- f. Install bilge drain plug in hull.
- 8. Align rear engine mounts with inner transom plate mounts while simultaneously aligning exhaust tube with intermediate elbows.
- 9. Install both rear engine mounting bolts and hardware and torque. Do not relieve hoist tension.

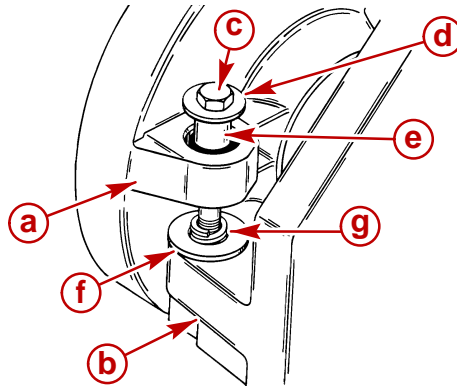

72535

- a - Rear Engine Mount
- b - Inner Transom Plate Mount
- c - Bolt
- d - Washer
- e - Spacer
- f - Fiber Washer
- g - Double-Wound Lockwasher

Description	Nm	lb-in.	lb-ft
Rear Engine Mounting Bolts	51		38

IMPORTANT: If quick drain oil fitting is within 1/2 in. (6 mm) of boat bottom, remove fitting and install drain plug from parts bag directly into oil pan.

- 10. Ensure quick drain oil fitting is more than 1/2 in. (6 mm) above the boat bottom.

Exhaust System

CAUTION

It is the responsibility of the boat manufacturer or installing dealer to properly locate the engine and install the exhaust system. Improper installation may allow water to enter the exhaust manifolds and combustion chambers and severely damage the engine. Damaged caused by the water in the engine will not be covered by Mercury MerCruiser Warranty, unless this damage is the result of defective parts.

MEASURING PROCEDURE

1. Fill all fuel, water, gray water and heater tanks to maximum capacity.

NOTE: Weight can be added in these locations to simulate full loaded condition.

2. Add maximum allowable cargo weight to boat in areas where it will be stowed, including refrigerator and lockers.
3. Add 190 lb (86 kg) of weight in all locations where each passenger will sit during normal operation.
4. Measure exhaust elbow height. Also, measure exhaust system slope on applications with through the hull or through the transom exhaust.

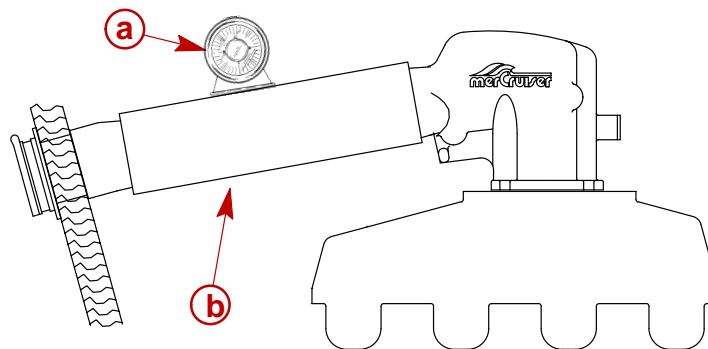

77981

Using A Universal Protractor (Inclinometer) To Measure Slope

- a** - Protractor
- b** - Exhaust Hose Or Tube

5. **On applications with through the propeller exhaust:** Proceed to Step 7.
6. **On applications with through the hull or through the transom exhaust:**
 - a. Move load weight to bow to simulate greatest bow-down attitude the boat will encounter in normal operation.
 - b. Recheck exhaust system slope.
7. Move load weight and cargo weight to stern of boat to stimulate greatest stern-down attitude the boat will encounter such as when loading.

IMPORTANT: Be sure to consider swim platform loading and personal watercraft.

8. Recheck exhaust system measurements.

Minimum Exhaust Elbow Height from Top of Elbow to Waterline	
Model	Measurement
All V6 and V8	13 in. (330 mm)

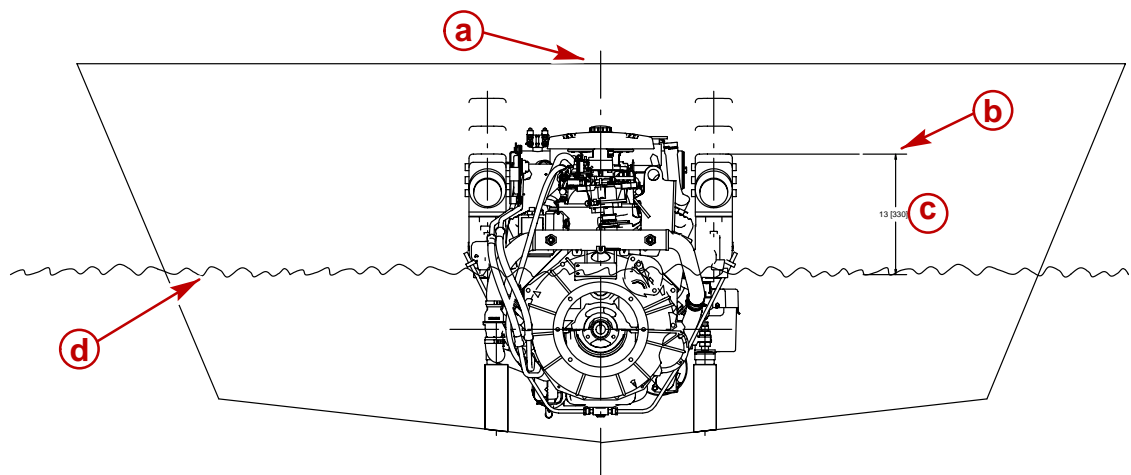

77956

- a** - Top Of Transom 70082
- b** - Highest Point On Exhaust Elbow
- c** - Measurement
- d** - Waterline

Additional requirements for through the hull or transom exhaust system applications:

Minimum Continuous Downward Slope (Exhaust Hoses, Collector, Etc.)	
Model	Measurement (degrees)
All Sterndrive	6

9. If measurements are less than specified, exhaust elbow risers must be installed to achieve proper dimension.

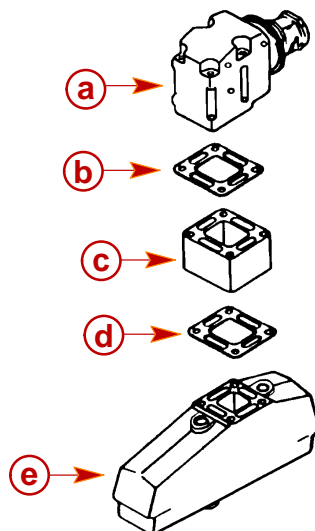

77991

Typical Riser Installation

- a** - Exhaust Elbow
- b** - Restrictor Gasket
- c** - Riser
- d** - Open Gasket (4 Slots)
- e** - Exhaust Manifold

NOTE: Up to a maximum of 9 in. (229 mm) of riser height can be added.

Methods for Measuring Exhaust Elbow Height

STRAIGHT EDGE METHOD

1. Place a straight edge across boat.
2. With the straight edge above the engine as shown, measure the distance between the straight edge and the top of the exhaust elbow.
3. Make sure that the boat is level from side-to-side, using a level or inclinometer. Then, measure the distance between the straight edge and the outside waterline.
4. The difference between these two measurements is the exhaust elbow height above the water line. Refer to Measuring Procedures and compare measurement to specifications.

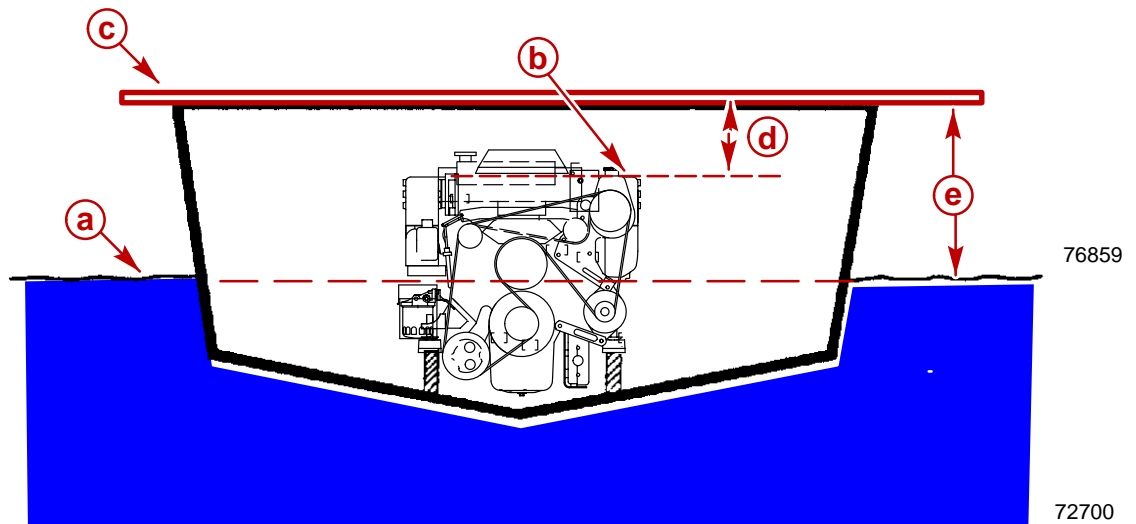

- a** - Waterline
- b** - Top Of Exhaust Elbow
- c** - Straight Edge
- d** - Measurement Between Straight Edge And Top Of Exhaust Elbow
- e** - Measurement Between Straight Edge And Water Line

CLEAR HOSE METHOD

1. Obtain a 5/16 - 3/8 in. (8-10 mm) long hose approximately 15 ft. (4.5 m) long. Put a metal fitting or a weight on one end of the hose to keep that end of the hose below the water line.
2. Put the weighted end of the hose over the port or starboard side of the boat, keeping it in line with the engine's exhaust elbow.
3. Route the remainder of the hose toward the engine's exhaust manifold and elbow. Ensure that this open end section of the hose is as vertical as possible from the boat's bilge to the top of the exhaust elbow
4. Coil excess hose in bilge of boat, keeping it below the water line.
5. Lower open end of hose and siphon water until it starts to come out of the hose. Put a finger over the hose and lift open end until it is at the top of the exhaust elbow.
6. Slowly take finger off end of hose to let the water level stabilize. The water will seek the level of the water outside the boat. Keep hose close to exhaust elbow and as vertical as possible.
7. Make sure that the boat is level (side-to-side) using a level or inclinometer.
8. The measurement between water in hose and top of exhaust elbow is the exhaust elbow height.

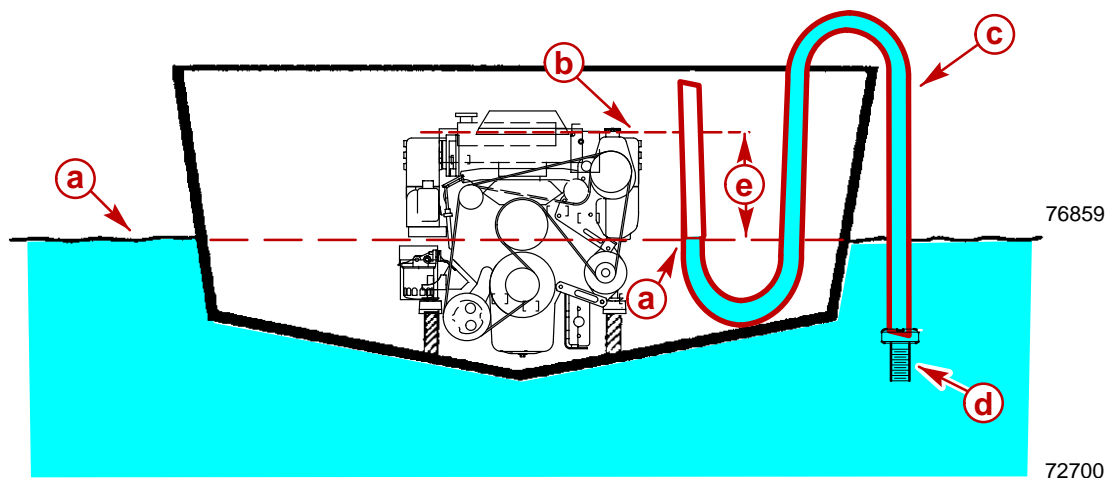

- a** - Waterline
- b** - Top Of Exhaust Elbow
- c** - Clear Plastic Hose
- d** - Weight
- e** - Measurement - Waterline To Top Of Exhaust Elbow

Exhaust System Hose / Tube Connections

⚠ CAUTION

Avoid exhaust hose failure. Discharge water from exhaust elbow must flow around entire inside diameter of hose to avoid causing hot spots which could eventually result in burned-through exhaust hoses. Exhaust hoses and/or tubes must be correctly connected to exhaust elbows so that they do not restrict the flow of discharge water from exhaust elbow.

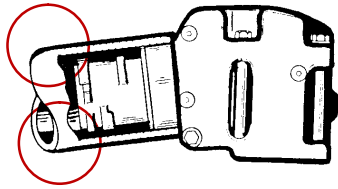

Correct Connection

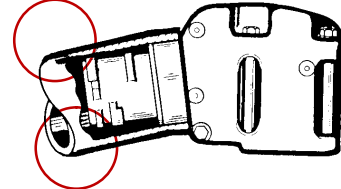

Incorrect Connection

71653

IMPORTANT: Exhaust hoses/tubes should be secured at each connection with at least 2 hose clamps.

1. Tighten all exhaust hose and/or exhaust tube clamps securely.

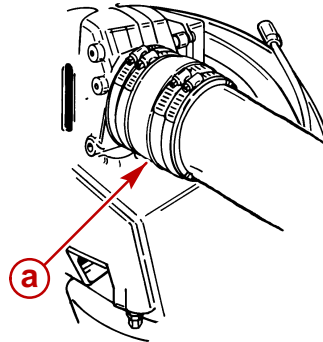

a - Hose Clamps

73961

Engine Alignment

1. Ensure that the dust cover is removed or folded back out of the way.

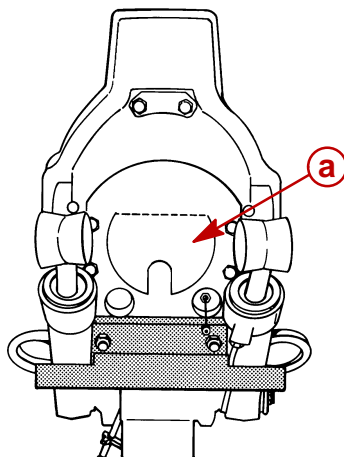

22027

a - Dust Cover

CAUTION

DO NOT use an alignment tool from another manufacturer. Alignment tools other than Quicksilver Alignment Tool may cause improper alignment and damage to gimbal bearing and/or engine coupler.

2. Attempt to insert the solid end of the alignment tool through the gimbal bearing and into the engine coupler splines.
3. If the tool does not fit, remove it and carefully raise or lower the front end of the engine using the center alignment eye and attempt to insert the alignment tool.

- Repeat step 3. until the alignment tool installs easily (**SLIDES FREELY WITH TWO FINGERS**) all the way into and out of engine coupler splines. Do not check by turning the alignment tool.

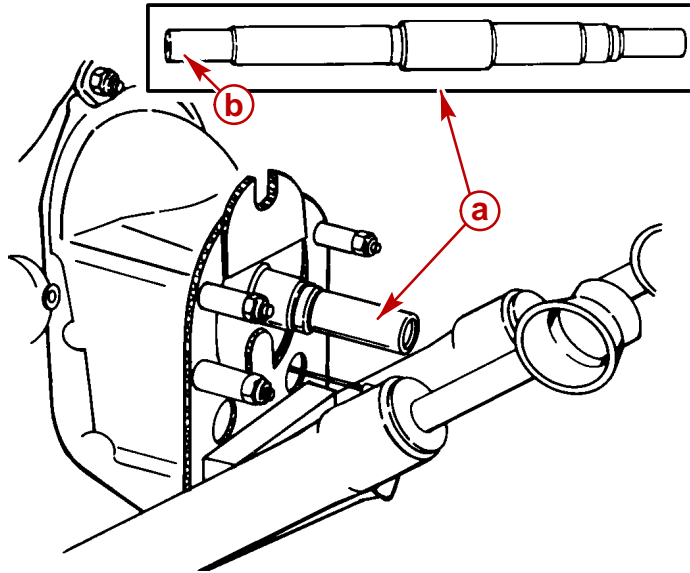

22029

- a** - Alignment Tool (Use Only Recommended Alignment Tool)
- b** - Insert This End Of Alignment Tool Through Gimbal Housing Assembly

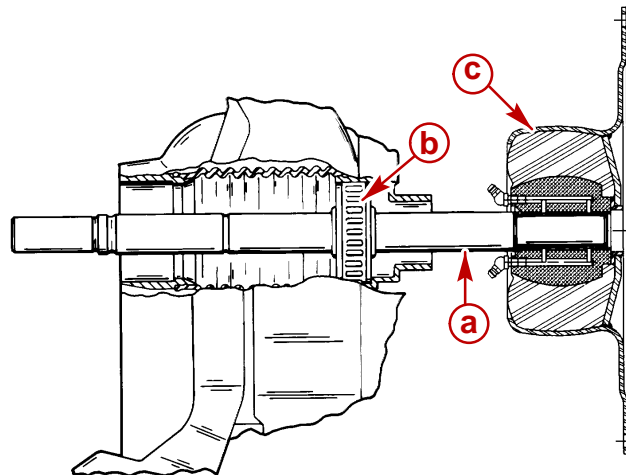

27647

- a** - Alignment Tool
- b** - Gimbal Bearing
- c** - Engine Coupler

IMPORTANT: Finished boat stringer must position engine so that a minimum mount adjustment exists after front mount is adjusted down to stringer. This allows for future adjustments.

5. 3.0L Center Mount Model:

- a. Set the engine on the stringer.
- b. Relieve the hoist tension.
- c. Attach the hoist to the center alignment eye.
- d. Fasten front mount to the stringer.
- e. Recheck alignment.
- f. Tighten locknut and jam nut securely.

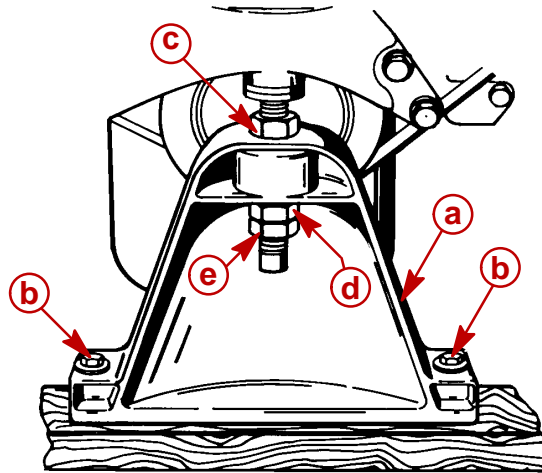

22054

3.0L Center Mount Model

- a** - Front Mount
- b** - Attaching Bolts and Flat Washers
- c** - Adjusting Nut
- d** - Locknut
- e** - Jam Nut

IMPORTANT: Turn both front engine mount adjustment nuts an equal amount in direction required to align engine.

6. All Other Models:

- a. Adjust front engine mounts until they rest on boat stringers.
- b. Relieve hoist tension entirely and fasten both front mounts to boat stringer using appropriate hardware.
- c. Tighten the bottom nut to hold the engine in place. Then release the tension.

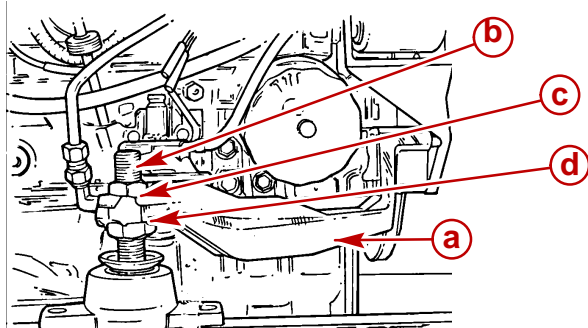

77968

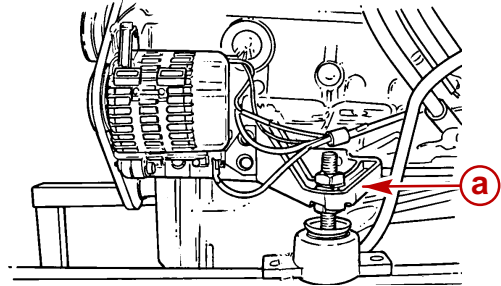

77970

3.0L Side Mount Model

- a** - Engine Mount
- b** - Bolt
- c** - Lockwasher
- d** - Tab Washer

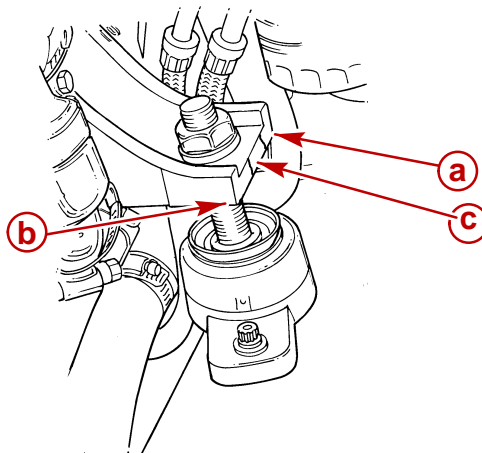

77913

V6 and V8 Models

- a** - Engine Mount
- b** - Bottom Nut - Not Visible
- c** - Tab

7. Recheck alignment with alignment tool. Tool must enter coupling splines freely. If not, readjust front mounts.
8. When alignment is correct, tighten locknut securely. Recheck alignment.
9. Bend tab down on adjusting nut.
10. Remove alignment tool. If not installing drive, fold bell housing dust cover flap back into place and tape shut for boat shipment. Dust cover flap will have to be removed before operating engine.
11. Hook up the ground stud.
12. Connect the trim pump sender wires.
13. Install the water inlet hose onto the transom.

Hot Water Heater Installation

IMPORTANT: When connecting a cabin heater or hot water heater:

- Supply hose (from engine to heater) and return hose (from heater to engine) **MUST NOT EXCEED 5/8 in. (16 mm) inside diameter (ID).**
- Make heater connections **ONLY** at locations shown.
- Refer to manufacturers' instructions for complete installation information and procedures.
- Do not reposition engine temperature switch.

⚠ CAUTION

Avoid a performance loss and/or possible engine damage. Engine coolant must flow continuously from the engine intake manifold to the engine water circulating pump. **NEVER** close-off or block the coolant flow to or from a heater.

⚠ CAUTION

Avoid engine overheating which could result in engine damage. On models equipped with Closed Cooling, an air pocket may form in the closed cooling system if some coolant is lost from the system and the cabin heater or hot water is mounted higher than the fill cap on the heat exchanger. Heater must be mounted lower than the fill cap of the heat exchanger on models so equipped.

SUPPLY HOSE CONNECTION

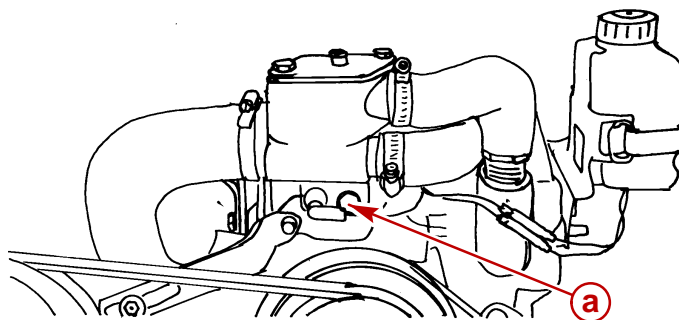

76095

3.0L

a - Location For Hot Water Supply (Install Bayonet Fitting Here)

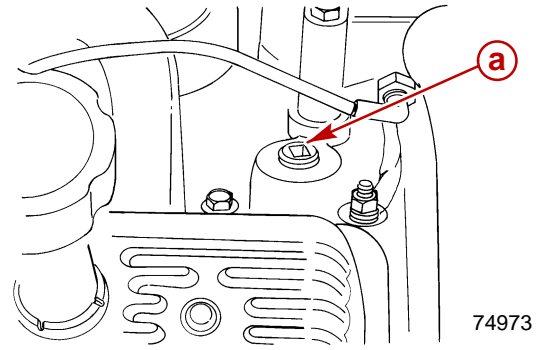
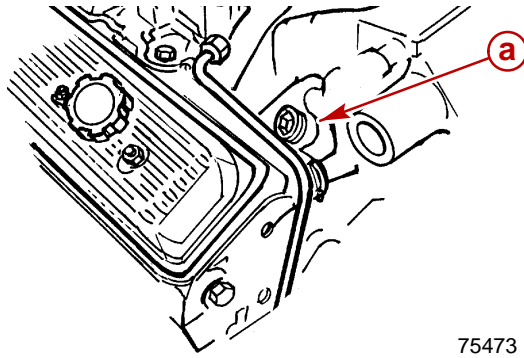

Seawater Cooling - If Location Is Available

a - Location For Hot Water Supply

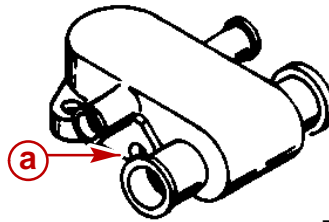

Seawater Cooling - Alternate Location

a - Location For Hot Water Supply

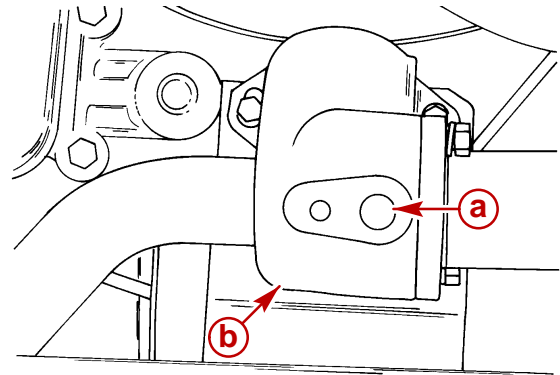
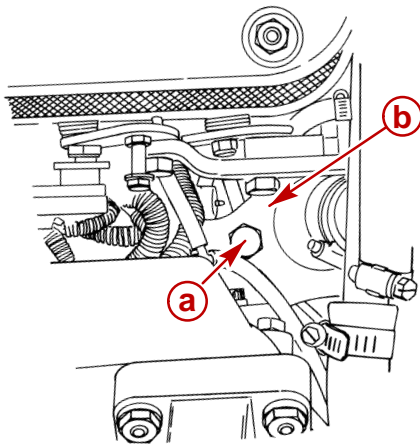

Closed Cooling Models - If Location Is Available

a - Location for Hot Water Supply (Bayonet Fitting Replaces Brass Plug)

b - Thermostat Housing

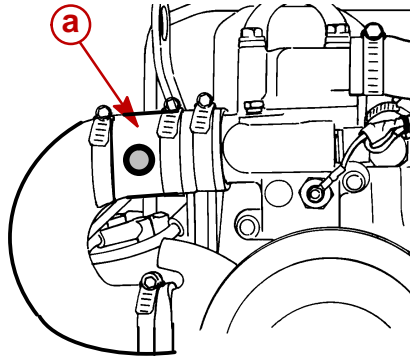
RETURN HOSE CONNECTION

73572

Typical 3.0L

a - Location For Hot Water Return (T-Fitting Installed in Water Circulating Pump Hose)

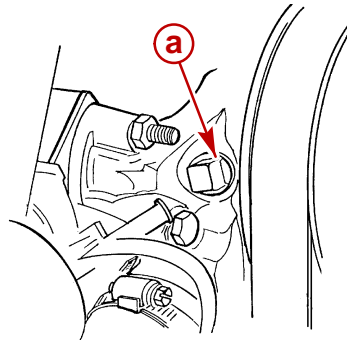

75480

Seawater or Closed Cooling System

a - Location For Hot Water Return

Electrical Connections

IMPORTANT: When routing all wire harnesses and hoses, be sure they are routed and secured to avoid coming in contact with hot spots on engine and to avoid contact with moving parts.

Installing Continuity Wire

1. Connect continuity circuit wire from engine to transom assembly.

IMPORTANT: Do not attach any accessory ground (-) wires to transom plate ground point. Accessory ground wires can only be attached to ground stud on engine.

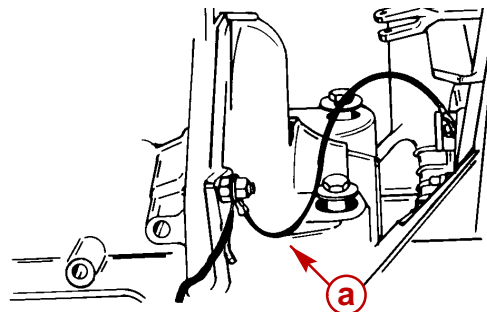

71651

a - Continuity Wire

Instrumentation Connections

We recommend the use of Quicksilver Instrumentation and Wiring Harnesses. On dual station applications, oil pressure and water temperature senders (on engine) must be changed. Refer to *Mercury Precision Parts / Quicksilver Accessories Guide* for selection.

The 4 basic gauges that must be used with the engine are:

- Tachometer
- Oil Pressure
- Water Temperature
- Voltmeter

IMPORTANT: Connect fused accessory panel (40-amp current draw maximum) must be connected as shown in the wiring diagrams.

1. Route instrumentation wiring harness back to engine, making sure that harness does not rub or get pinched. If an extension harness is required, be sure to secure connection properly.
2. Fasten harnesses to boat at least every 18 in. (460 mm), using appropriate fasteners.
3. Place hose clamp over instrumentation wiring harness.
4. Connect the instrumentation wiring harness to engine harness plug at location shown.

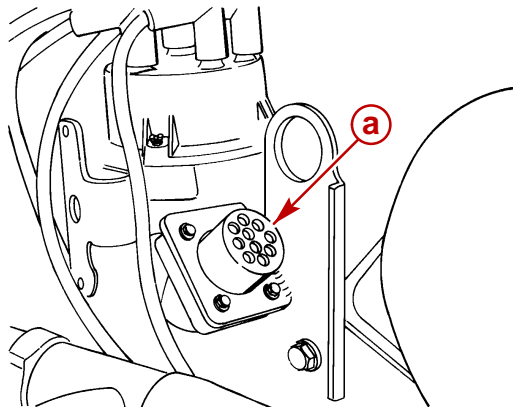

74754

Typical

a - Wiring Harness Connector

5. Tighten hose clamp to secure wiring harness to engine harness plug.

Trim Position Sender Connections

1. Connect trim position sender wires (from transom assembly) to engine harness.

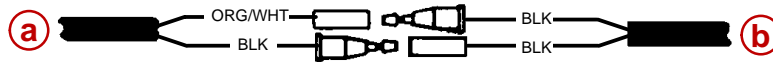
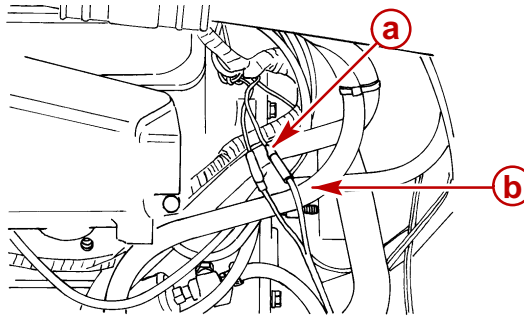

74029

- a** - Engine Harness Bullet Connector
- b** - Transom Assembly Bullet Connector

MerCathode Connections (If Equipped)

1. Connect wires to MerCathode controller assembly as shown. Apply a thin coat of Liquid Neoprene to all connections.

IMPORTANT: Opposite end of RED/PURPLE wire must be connected directly to battery positive (+) terminal. DO NOT connect it to a switched positive (+) circuit. MerCathode system must function continuously for proper corrosion protection.

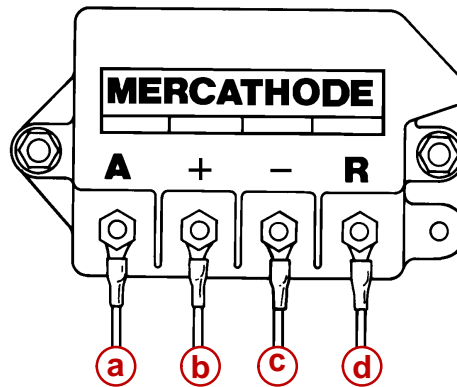

22232

- a** - ORANGE Lead - From Electrode On Transom Assembly
- b** - RED/PURPLE Wire - To Positive (+) Battery Terminal
- c** - BLACK Wire - From Engine Harness
- d** - BROWN Wire - From Electrode On Transom Assembly

Description	Where Used	Part Number
A Liquid Neoprene	MerCathode Connections	92-25711-2

Audio Warning System Connections

⚠ WARNING

Alarm is not external ignition-proof, therefore, DO NOT mount alarm in engine or fuel tank compartments.

- Select a location for audio warning alarm which meets all of the following:
 - alarm can be easily heard, yet is out of sight
 - alarm can be easily accessed for installation and maintenance
 - alarm will remain dry
 - alarm is within length limits of the 18 in. purple alarm wire that connects to the "I" terminal or 12 volt source on switched side of ignition switch.

NOTE: The terminal to which wire is attached must have no voltage when ignition switch is in the OFF position.

- Place alarm in desired location and secure to wire bundle with tie-strap provided.
- Connect PURPLE wire from alarm to any PURPLE wire terminal on instrument gauge or ignition switch. Tighten connection securely.
- Connect TAN/BLUE wire from alarm to TAN/ BLUE wire from instrument harness.
- Place the small (transparent) decals on the bottom of the water temperature and the oil pressure gauges.
- Place the large decal on the instrument panel or other appropriate location in easily viewed by the operator.

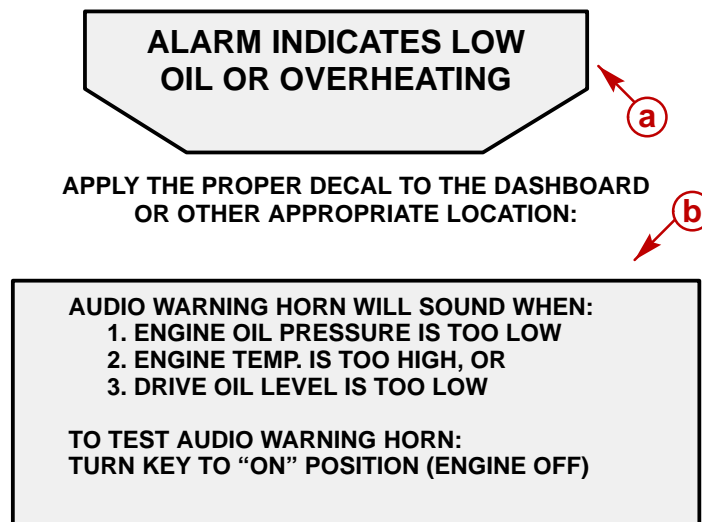

75430

- a** - Small Decal (Transparent)
- b** - Larger Decal

- Test audio warning system during Predelivery Preparation section.

Power Trim Pump Connections

IMPORTANT: Make hydraulic connections as quickly as possible to prevent oil from leaking out of system. Be careful not to cross-thread or overtighten hose fittings.

1. Connect hydraulic hoses to trim pump. Torque fittings.

Description	Nm	lb-in.	lb-ft
Fittings	14	125	

2. Connect power trim pump control harness to trim pump.

3. Connect trim limit switch wires and secure with wire retainer and tie-strap.

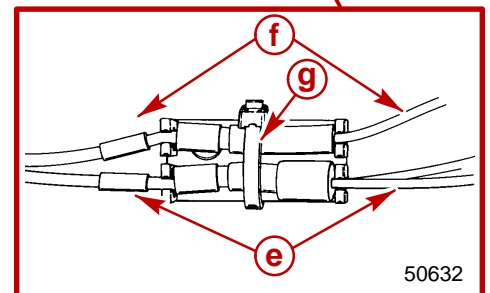
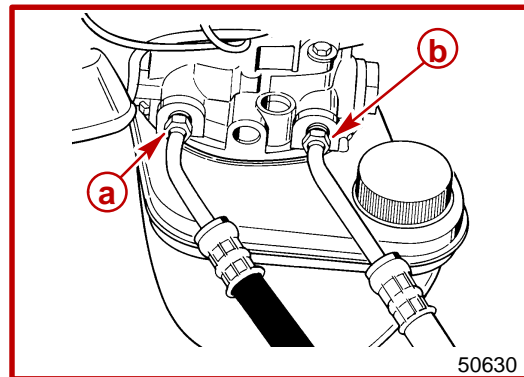
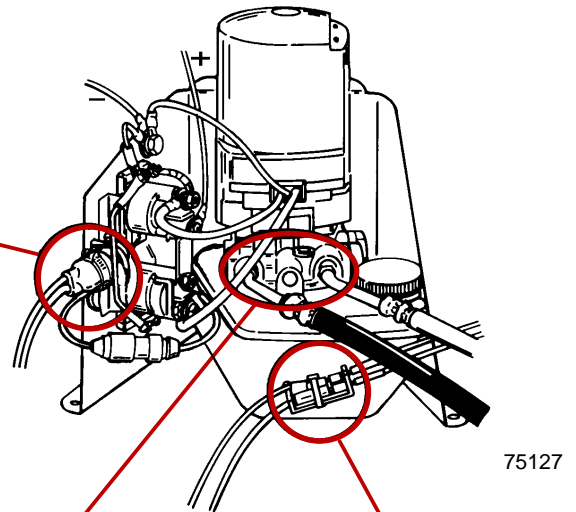
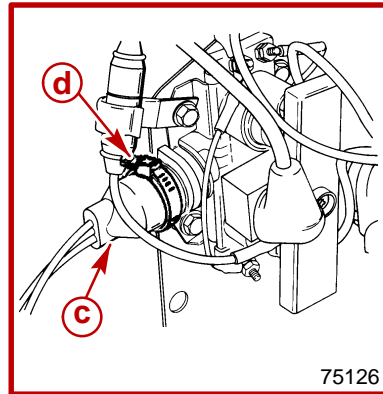

- a** - Black Hose Fitting (UP Circuit)
- b** - Gray Hose Fitting (DOWN Circuit)
- c** - Control Harness
- d** - Tie-Strap
- e** - Trim Limit Switch Wire (With Blue Sleeve) To BLUE/WHITE Harness Wire
- f** - Trim Limit Switch Wire (With Purple Sleeve) To PURPLE/WHITE Harness Wire
- g** - Wire Retainer And Tie Strap

4. Unscrew fill cap and **remove** cap plug from fill neck and **discard**. Install fill cap.

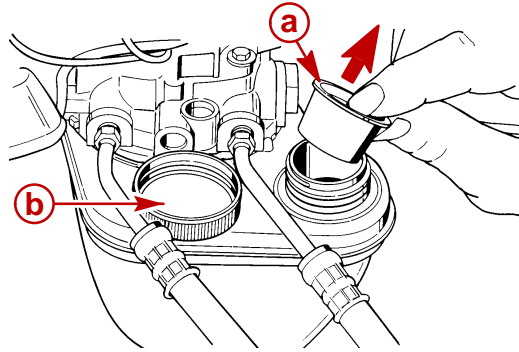

50630

- a** - Capplug
- b** - Fill Cap

5. Connect power trim pump wires to battery.

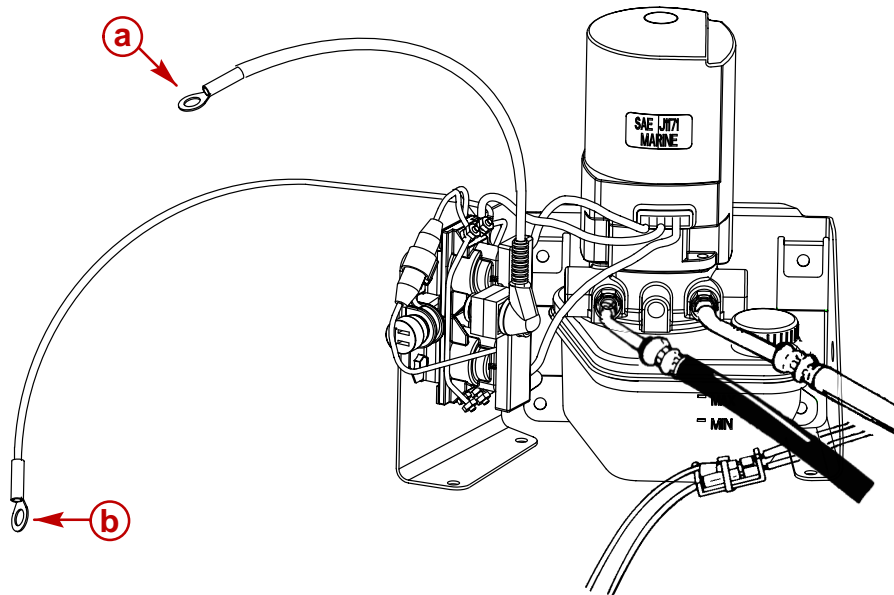

76631

- a** - Positive Battery Lead
- b** - Negative Battery Lead

Fluid Connections

Gear Lube Monitor Hose

IMPORTANT: Avoid using excessive hose when routing it to gear lube monitor. Hose should be routed directly to oil reservoir in as straight a line as possible to avoid low spots (traps) in the system.

⚠ CAUTION

Ensure hose is not kinked when connecting in the following step. If hose is kinked, gear lube monitor will not function properly and damage to drive unit could occur.

1. Route hose to gear lube monitor and cut off excess hose. Hose can be routed on outside of remote oil filter or the hole in the front lifting eye bracket.
2. Connect hose and secure with hose clamp.

IMPORTANT: Hose must not come in contact with steering system components or the engine coupler, U-joint shaft or drive shaft.

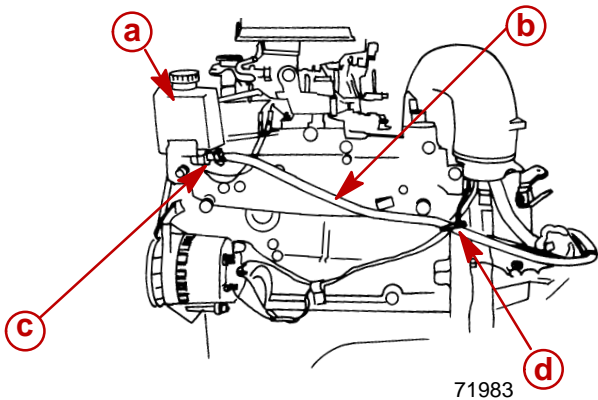

181 CID/3.0L Model

- a** - Gear Lube Monitor
- b** - Hose
- c** - Clamp
- d** - Sta-Strap

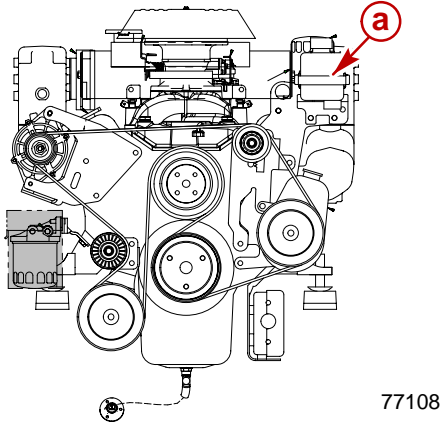

Typical

3. Use extra hose clips to secure hose to transom.

Power Steering Hoses

⚠ CAUTION

Route hoses exactly as shown below. This will help avoid stress on the hose fittings and will help avoid kinks in the hose.

IMPORTANT: Make hydraulic connections as quickly as possible to prevent fluid leakage.

IMPORTANT: Be careful not to cross-thread or overtighten fittings.

1. Route hoses. Secure hoses to avoid contact with moving components.
2. Connect power steering hoses to control valve. Torque both fittings.

Description	Nm	lb-in.	lb-ft
Fittings	31		23

3. Use extra hose clips to secure hose to transom.

NOTE: Power Steering Fluid can be added at this point, if desired.

Bravo Models and Alpha Seawater Cooled Models Using Sterndrive Water Pickups

1. Connect water hose to water inlet fitting.
2. Secure with hose clamp.

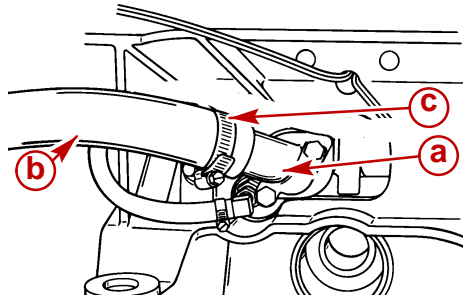

- a** - Water Inlet Fitting
- b** - Hose
- c** - Hose Clamp

72040

Alpha or Bravo Models Using Alternative Water Pickups

A water inlet block-off kit must be used if the sterndrive unit water pickup will not be used to supply water to the engine. When installing the block-off plate, it is necessary to cut the water hose that is located between the bell housing and the gimbal housing. This allows water to continue to circulate through the sterndrive unit for cooling.

⚠ CAUTION

Avoid overheating sterndrive. The seawater inlet holes must be allowed to flow water without being obstructed or overheating damage to sterndrive may result. Do not dead-end seawater hose from bell housing. Cut hose as recommended in procedures.

1. Remove the existing water fitting and gasket. Discard the screws and washers.

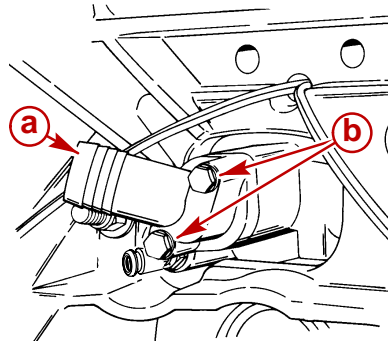

50663

- a** - Water Fitting
- b** - Screws And Lockwashers

2. Remove the tapered insert in the gimbal housing using the tapered insert tool (91-43579). Discard the insert.

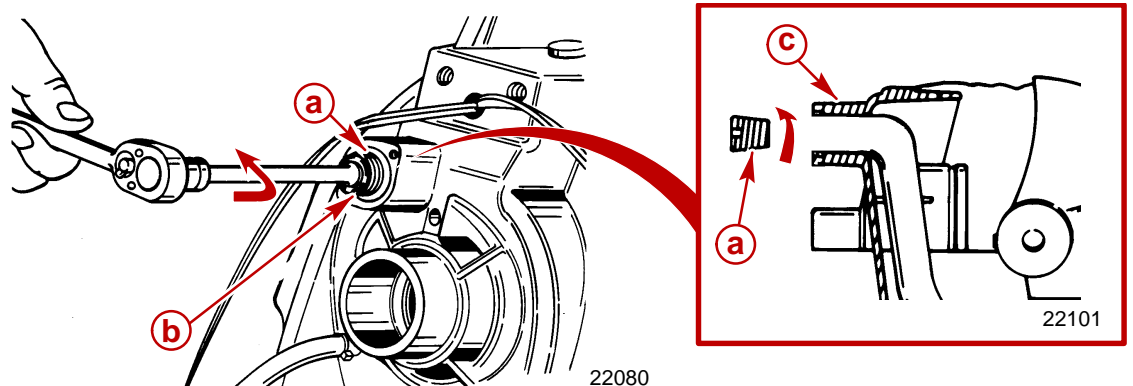

- a** - Tapered Insert
- b** - Tapered Insert Tool
- c** - Gimbal Housing Cross-Sectional View

Description	Part Number
Tapered Insert Tool	91-43579

3. Install the block-off plate with new gasket. Secure with screws and lockwashers. Torque the screws.

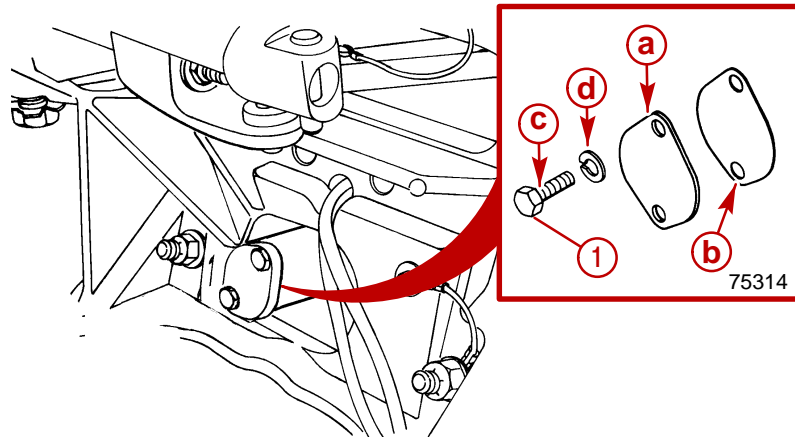

75313

- a** - Block-Off Plate
- b** - Gasket
- c** - Screw
- d** - Lockwasher

Description		Nm	lb-in.	lb-ft
1	Screw, Water Fitting	5	45	

4. Move the trim limit switch wires and speedometer hose aside. Reach between the gimbal housing and the bell housing and detach the water hose from the gimbal housing where the tapered insert was removed in Step 2.

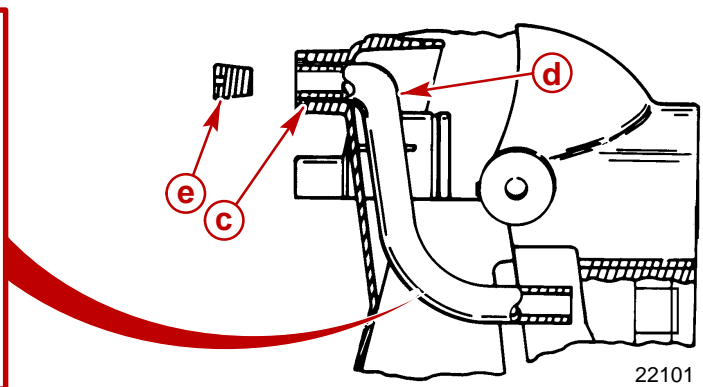
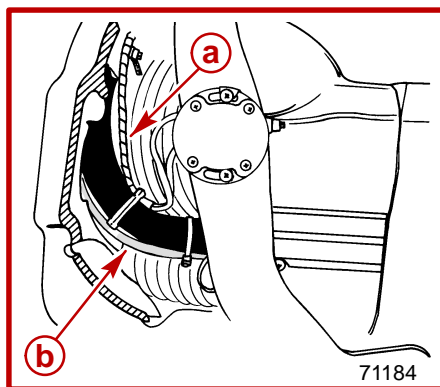

- a** - Trim Limit Switch Wires
- b** - Speedometer Hose
- c** - Gimbal Housing
- d** - Water Hose
- e** - Tapered Insert

⚠ WARNING

Avoid water leakage into boat. Damage to U-joint bellows could result in water entering the boat. Do not damage the U-joint bellows when removing a section of the water hose attached between the gimbal housing and bell housing.

NOTE: Move the trim limit switch wires and speedometer hose to avoid damaging them when cutting the water hose. The existing tie strap and clip can be reused if they are moved and repositioned after the hose is cut.

5. Cut completely through the water hose 5 in. (127 mm) in front of the aft end of the hose where it is fitted into the bell housing, in the area shown. DO NOT damage the U-joint bellows. Discard loose hose piece.
6. Secure the trim limit switch wires and speedometer hose to the remaining section of water hose using existing tie strap and clip.

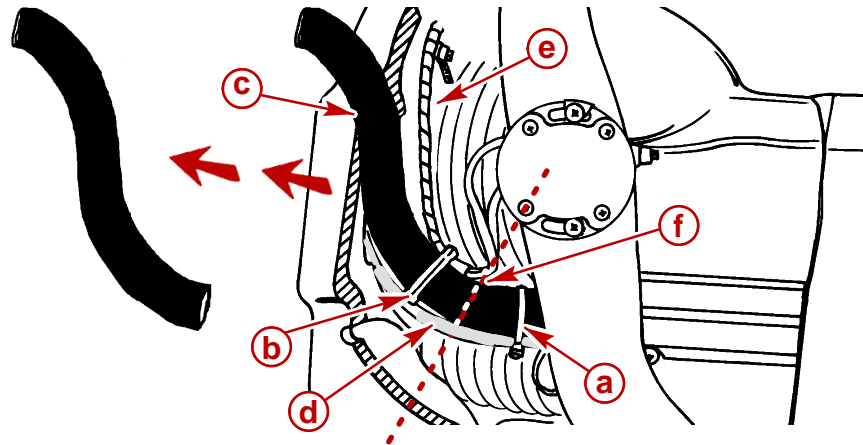

71184

- a** - Tie Strap
- b** - Clip
- c** - Water Inlet Hose
- d** - Speedometer Hose
- e** - Trim Limit Wire Harness
- f** - Cutting Area

Coolant Recovery System

⚠ CAUTION

Avoid engine overheating and subsequent damage to engine. The coolant recovery system will not operate properly without proper sealing. Plastic tubing **MUST** seal *completely* at connections.

1. Connect plastic tubing to bayonet fitting on heat exchanger. Secure with tubing clamp provided.

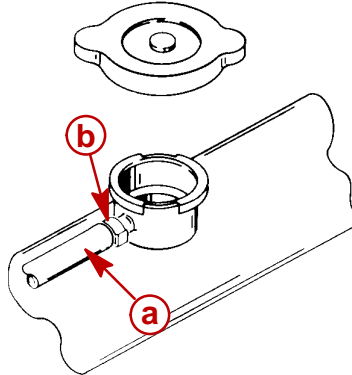

70548

- a** - Plastic Tubing
- b** - Tubing Clamp

1. Remove cap from coolant recovery reservoir and fill to FULL mark with coolant solution.
2. Reinstall cap.

Shift Cable Installation

Alpha Models - Drive Unit Not Installed

We recommend the use of a Quicksilver remote control and cable. Refer to *Mercury Precision Parts / Quicksilver Accessories Guide* for selection. However, if a control other than Quicksilver is to be used, control must provide a shift cable travel (at the shift plate end) of 2-7/8 in. (73 mm) to 3-1/8 in. (80 mm) with a 15-20 lb. (6.8-9 kg) load applied to the cable end guide.

NOTE: On engines with Alpha drives, the measurement indicated above can be taken by installing the remote control shift cable and using the shift assist assembly (provided) to place the proper load on the shift cable.

1. Place a mark on the tube against the edge of the cable end guide.

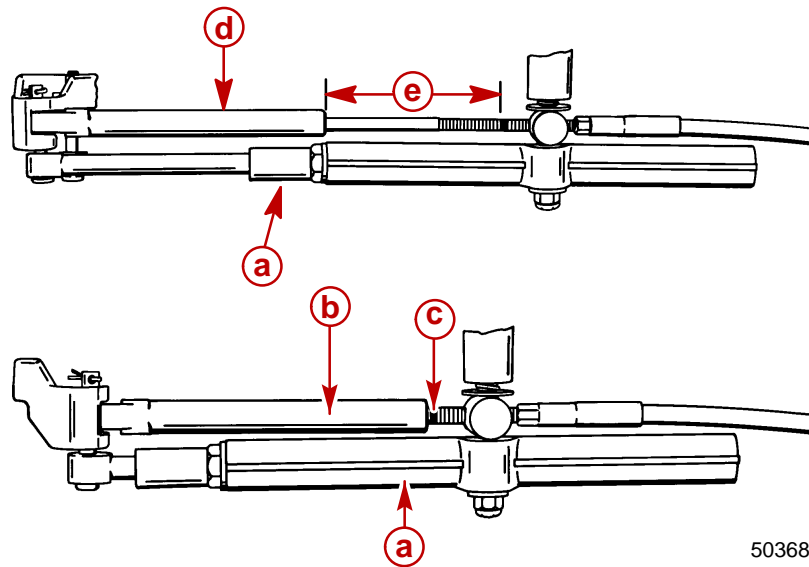

50368

- a** - Shift Assist Assembly
- b** - Remote Control Shift Cable - In FORWARD Gear Position
- c** - Edge Of Cable End Guide
- d** - Remote Control Shift Cable - In REVERSE Gear Position
- e** - Measurement Taken From Mark To Edge Of Cable End Guide:
2-7/8 in. (73 mm) to 3-1/8 in. (80 mm)

IMPORTANT: If boat is being equipped with a REMOTE CONTROL THAT HAS SEPARATE SHIFT AND THROTTLE LEVERS, the shift assist assembly that is shipped with the engine should NOT be used. The use of the shift assist assembly with this type of remote control can cause the shift lever to move out of gear unexpectedly.

The following kit will have to be ordered to connect remote control shift cable when shift assist assembly is not used.

Spacer Kit 23-11284A1

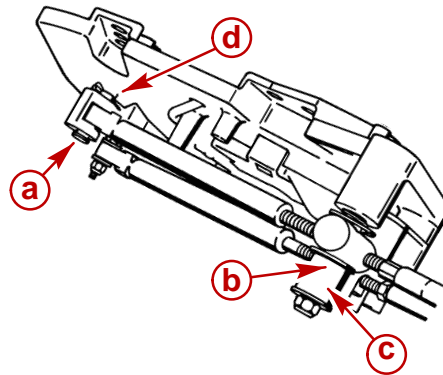

50310

- a - Clevis Pin
- b - Washer
- c - Spacer
- d - Cotter Pin

NOTE: Do not discard shift assist assembly until after it is used in step 3., following.

IMPORTANT: Shift cable must be connected at the remote control for the appropriate rotation (LH or RH) drive unit, as explained following:

RIGHT HAND ROTATION - Control cable will have to be installed in remote control so that cable end will move in direction "A" when shift handle is placed in the FORWARD position.

LEFT HAND ROTATION - Control cable will have to be installed in remote control so that cable end will move in direction "B" when shift handle is placed in the FORWARD position.

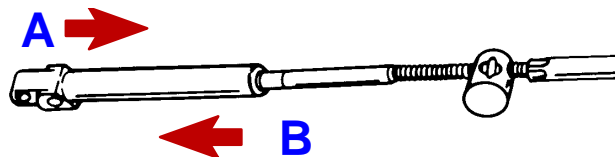

71656

IMPORTANT: Use the following procedure to temporarily install shift cables if boat will be shipped without drive unit installed. Refer to Shift Cable Installation for shift cable adjustment procedure once drive unit is installed.

1. Remove shift cable attaching hardware.

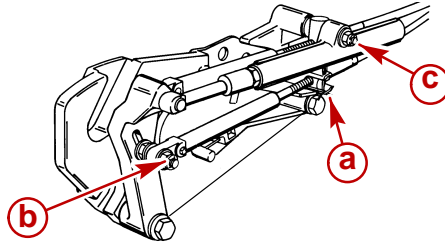

50308

- a** - Cotter Pin
- b** - Clevis Pin And Cotter Pin
- c** - Washer And Locknut

2. Place remote control shift lever in NEUTRAL position.
3. Temporarily install clevis pin through remote control shift cable end guide, shift assist assembly end and into hole in shift lever. Then adjust brass barrel so that hole in barrel aligns with anchor stud.

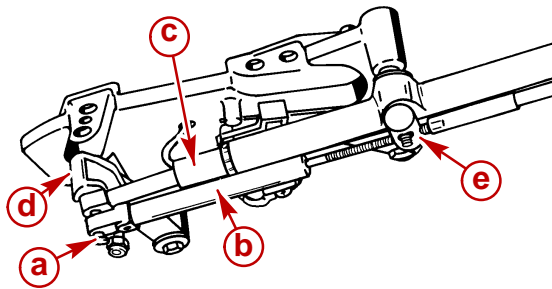

50308

- a** - Clevis Pin
- b** - Shift Cable End Guide
- c** - Shift Assist Assembly End
- d** - Shift Lever
- e** - Brass Barrel (On Stud)

4. Remove remote control shift cable and shift assist assembly.

IMPORTANT: Install the cotter pin through the top of the barrel retainer.

5. Install drive unit shift cable as shown. Secure brass barrel in barrel retainer with cotter pin and spread both prongs. Secure cable end guide with washers (one on each side of end guide) and locknut. Tighten locknut until it contacts, then loosen 1/2 turn.

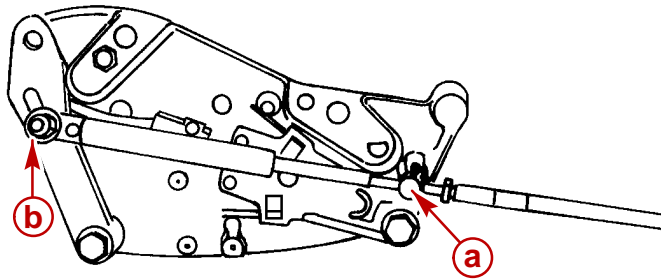

75415

Without Shift Assist Assembly

- a** - Cotter Pin
- b** - Locknut And Washers

- Install remote control shift cable (with or without shift assist assembly as applicable) and secure with hardware as shown. Tighten locknut finger tight only and do not spread cotter pin completely. (Remote control shift cable fasteners will have to be removed again to properly adjust shift cables under Shift Cable Installation section of this manual.)

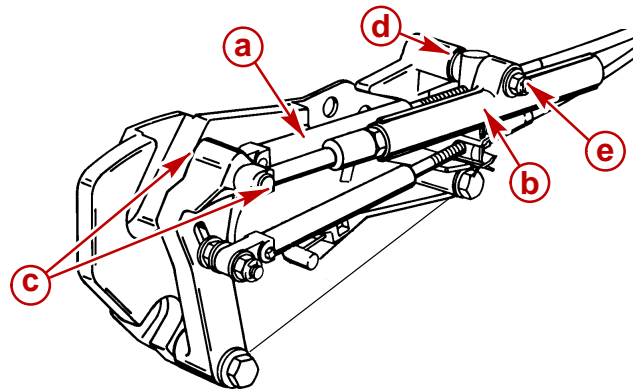

50308

With Shift Assist Assembly

- a** - Remote Control Shift Cable
- b** - Shift Assist Assembly
- c** - Clevis Pin And Cotter Pin
- d** - Large I.D. Washer
- e** - Small I.D. Washer And Locknut

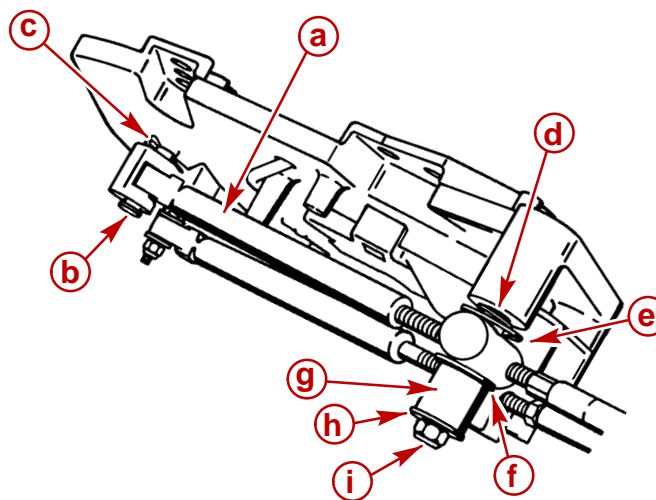

50310

Without Shift Assist Assembly

- a** - Remote Control Shift Cable
- b** - Pin
- c** - Cotter Pin (Existing)
- d** - Spring (Existing)
- e** - Washer (Existing)
- f** - Washer
- g** - Spacer
- h** - Washer (Existing)
- i** - Locknut (Existing)

Bravo Models

NOTE: Using Adjustment Tool (91-12427), shift cables can be adjusted without or with the sterndrive installed, using the following procedure.

IMPORTANT: Sterndrive unit propeller rotation is determined by the shift cable installation in the remote control.

- **Bravo One/Two** - If shift cable end guide moves in direction **A** when control lever is placed in FORWARD, remote control is set up for RIGHT HAND (RH) propeller rotation.
- **Bravo One/Two** - If shift cable end guide moves in direction **B** when control lever is placed in FORWARD, remote control is set up for LEFT HAND (LH) propeller rotation.

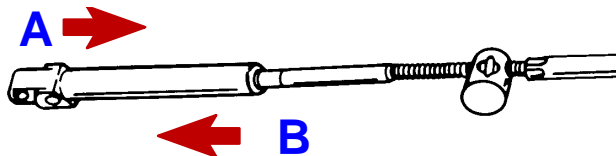

71656

Arrow Indicates Direction Of Motion

- **Bravo Three** - Front propeller on sterndrive unit is always LH Rotation and rear propeller is always RH Rotation. Shift cable end guide must move in direction **A**, when control lever is placed in FORWARD gear position.

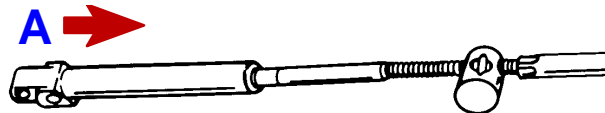

71656

IMPORTANT: When installing shift cables, be sure that cables are routed in such a way as to avoid sharp bends and/or contact with moving parts. DO NOT fasten any items to shift cables.

1. Install shift cable into remote control. (Refer to appropriate remote control instructions.)
2. Remove the guide.
3. Loosen stud and move it to dimension, as shown. Retighten stud.

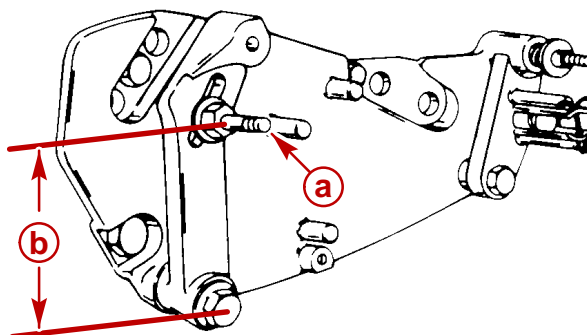

71657

a - Stud

b - 3 in. (76 mm) (Center Of Pivot Bolt To Center Of Stud)

4. Install sterndrive unit shift cable.
5. Tighten locknut until it contacts and then loosen 1/2 turn.
6. Insert cotter pin from top and spread ends.

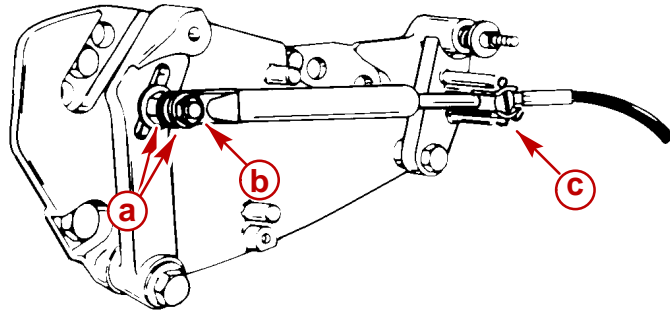

71658

- a** - Washers (2)
- b** - Locknut
- c** - Cotter Pin

7. Place adjustment tool over sterndrive unit shift cable, as shown. Hold tool in place, using a piece of tape over the barrel retainer.

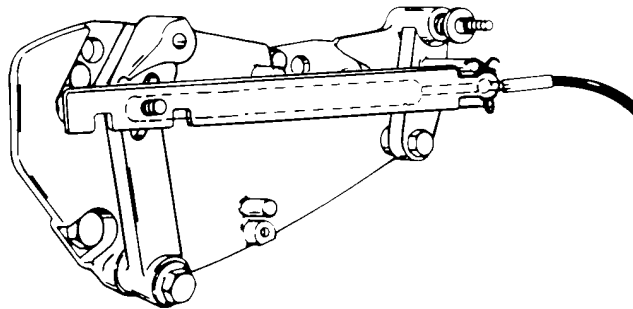

71659

8. Locate center of remote control and control cable play (backlash).

IMPORTANT: Be sure to keep center mark "c" aligned with control cable end guide edge when making the following adjustment.

- a. Shift remote control to NEUTRAL.
- b. Push in on control cable end with enough pressure to remove play and mark position "a" on tube.
- c. Pull out on control cable end with enough pressure to remove play and mark position "b" on tube.
- d. Measure distance between marks "a" and "b" and mark position "c" half-way between marks "a" and "b."

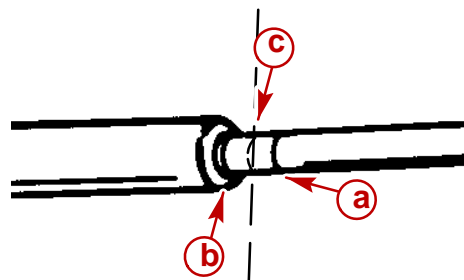

71656

9. Temporarily install control cable end guide into shift lever and insert anchor pin.
10. Adjust control cable barrel so that hole in barrel centers with vertical centerline of stud. Ensure that backlash center mark is aligned with edge of control cable end guide.

⚠ CAUTION

DO NOT attempt to install or remove control cable barrel from stud without first removing end guide anchor pin from shift lever and removing cable. Attempting to bend control cable to install or remove barrel will place undue stress on cable end guide and shift lever and damage to both could occur.

11. Remove control cable end guide from shift lever by removing anchor pin.

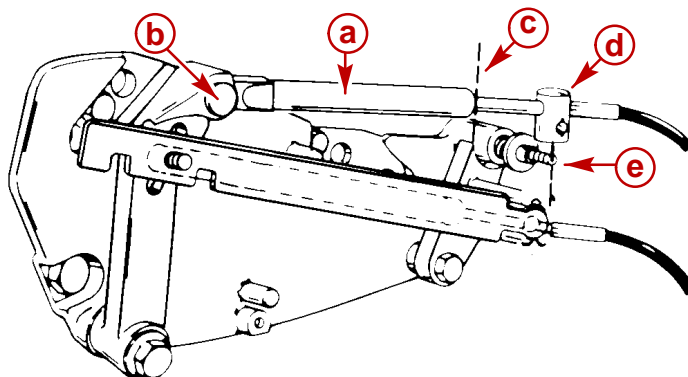

71660

- a** - Control Cable End Guide
- b** - Anchor Pin
- c** - Backlash Center
- d** - Control Cable Barrel
- e** - Stud

12. Install control cable.
13. Install washer and locknut.
14. Tighten locknut until it contacts and then loosen 1/2 turn.
15. Insert cotter pin from top and spread ends.

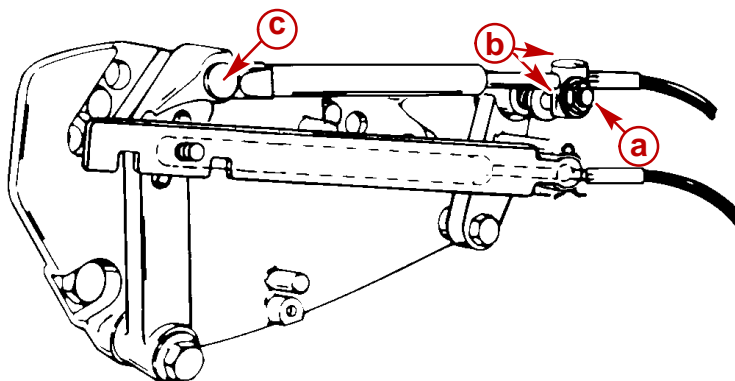

71661

- a** - Locknut
- b** - Washers - Both Sides Of Barrel
- c** - Anchor Pin
- d** - Cotter Pin (Not Shown)

16. Remove adjustment tool.
17. Shift remote control lever into full FORWARD position. Place end of adjustment tool in barrel retainer.

RH rotation Bravo One, Two and Three Models: Rear slot in tool should fit over shift lever stud.

LH rotation Bravo One And Two: Forward slot in tool should fit over shift lever stud.

If slot does not fit over stud, loosen shift lever stud and slide stud up or down until slot in tool fits over stud. When adjustment is correct, retighten stud.

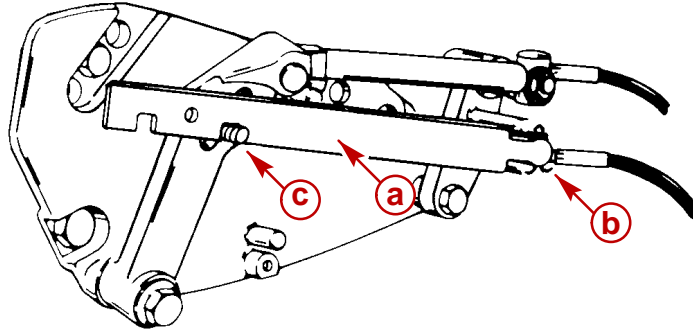

71662

RH Rotation Bravo One, Two, Three

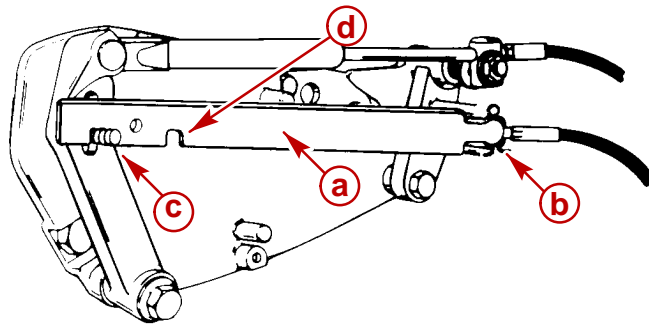

71663

LH Rotation Bravo One And Two

- a** - Adjustment Tool
- b** - Barrel Retainer
- c** - Shift Lever Stud
- d** - Shift Lever Adjustment Slot

18. Remove adjustment tool.
19. Lubricate shift cable pivot points.

Description	Where Used	Part Number
SAE 30W Engine Oil	Shift Cable Pivot Points	Obtain Locally

Throttle Cable Installation and Adjustment

1. Place remote control handle(s) in neutral/idle position.

IMPORTANT: Be sure that cable is routed to avoid sharp bends and/or contact with moving parts. DO NOT fasten any items to throttle cable. Outer cable must be free to move when cable is actuated.

2. Adjust cable so that it can be placed on both studs simultaneously.
3. Place cable over studs. DO NOT adjust cable after installation.
4. Secure throttle cable with hardware as shown. DO NOT overtighten as cable must pivot freely. Tighten until nut contacts, then loosen 1/2 turn.
5. Place remote control throttle lever in the wide open throttle (WOT) position. Ensure that throttle shutters are completely open.
6. Return remote control throttle lever to idle position and ensure that throttle lever contacts idle speed adjustment screw.

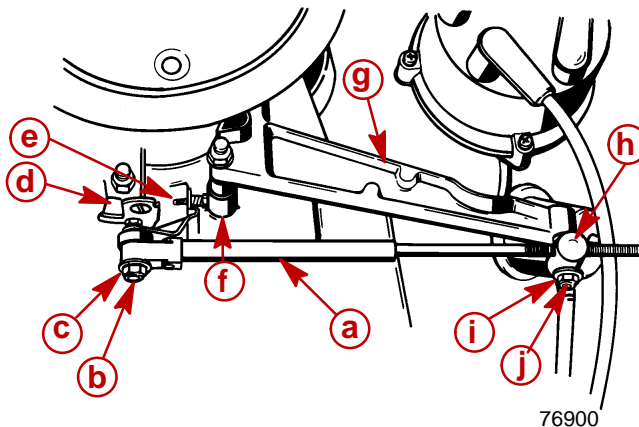

2 BBL V6 and V8 Models

- a** - Cable End Guide
- b** - Throttle Lever Screw
- c** - Locknut and Flat Washer (Small)
- d** - Throttle Lever
- e** - Idle Speed Adjustment Screw
- f** - Idle Cam
- g** - Throttle Bracket
- h** - Cable Barrel
- i** - Flat Washer and Locknut (Large)
- j** - Throttle Cable Anchor Stud

Sterndrive Unit Installation

1. Remove trim cylinder support and dust cover from bell housing studs. (Retain elastic stop nuts and flat washers.)
2. Remove gear lube monitor cap. Fill with lubricant.

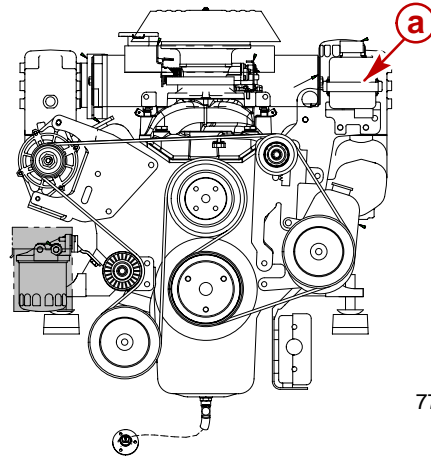

77108

a - Gear Lube Monitor

Description	Where Used	Part Number
A High Performance Gear Lube	Gear Lube Monitor	92-802853A1

3. Push dribble valve stem in until gear lube appears.

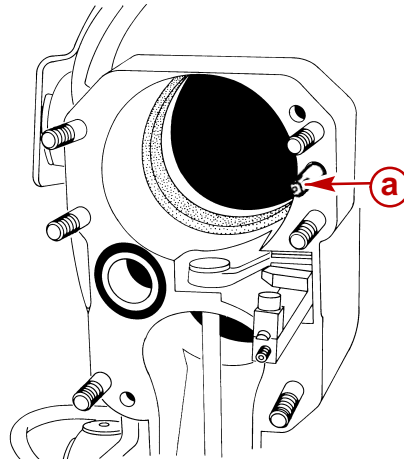

75531

a - Dribble Valve Stem

4. Once gear lube appears, release dribble valve stem.
5. Fill monitor to FULL mark.
6. Replace monitor cap.

IMPORTANT: Rubber gasket must be properly positioned in bell housing bore before installing drive unit or water may leak into boat.

- Alpha Models:** Ensure that rubber gasket and water passage O-ring are properly positioned in bell housing.

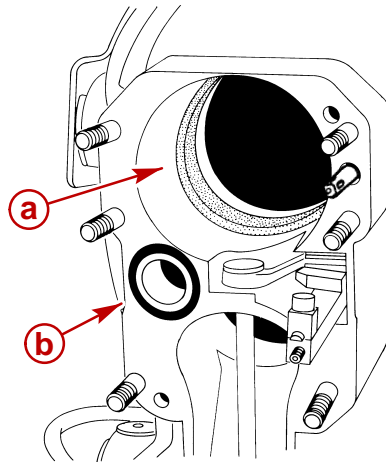

75531

- a** - Rubber Gasket
- b** - Water Passage O-ring

- Coat sterndrive unit pilot, U-joint O-rings and drive shaft splines.

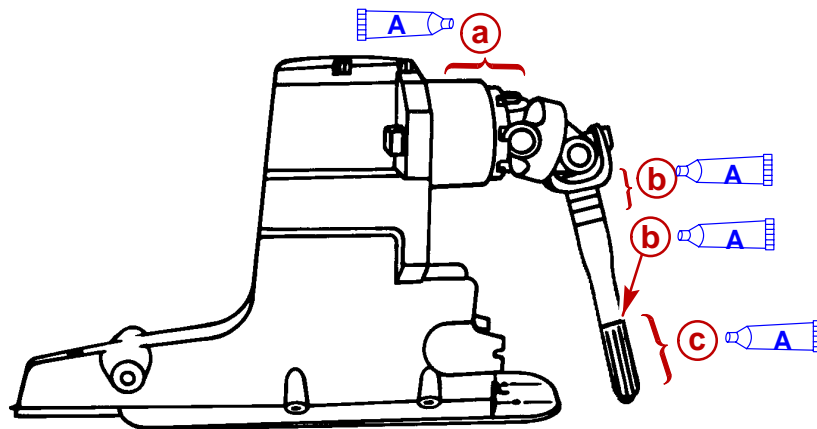

70114

- a** - Sterndrive Unit Pilot
- b** - O-rings
- c** - Splines

Description	Where Used	Part Number
A Engine Coupler Spline Grease	Drive Unit Pilot	92-816391A4
	U-Joint O-rings	
	Drive Shaft Splines	

9. Ensure drive shaft bellows are clean and free of debris.

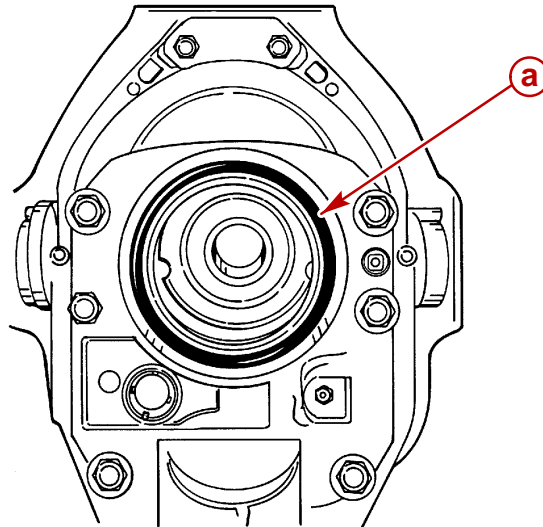

72472

a - Drive Shaft Bellows

Alpha Models

1. Position bell housing shift shaft coupler so that slot in coupler is positioned straight fore and aft. Do this by placing remote control shift lever in: **FORWARD gear position for RH drive or REVERSE gear position for LH drive unit.**

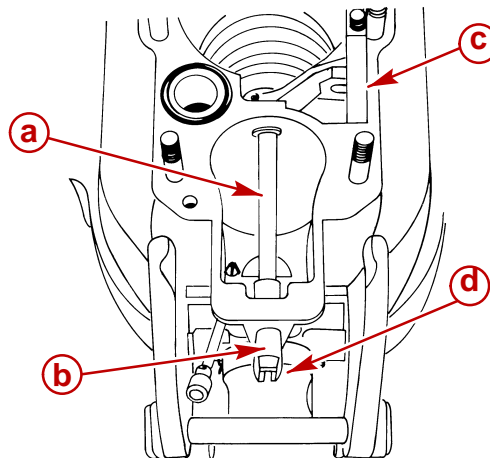

75525

a - Shift Shaft
b - Shift Shaft Coupler
c - Shift Slide
d - Slot

IMPORTANT: Shift slide assembly is free to rotate on core wire. Ensure that shift slide remains in upright position and is properly engaged with shift shaft lever roller while installing drive unit.

- Engage shift shaft roller into shift shaft lever. Snap the Shift Shaft Slide Stabilizer Tool onto stud directly below shift slide and position as shown.

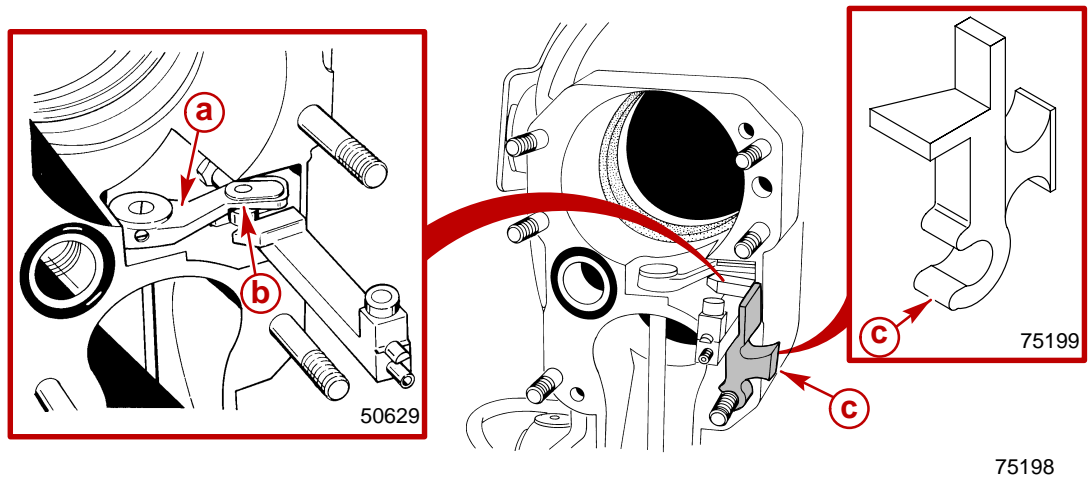

- a** - Shift Shaft Lever
- b** - Roller
- c** - Shift Shaft Slide Stabilizer Tool

Description	Part Number
Shift Shaft Slide Stabilizer Tool	91-809815A1

- Position drive unit shift shaft so that it is straight forward by turning shift shaft **CLOCKWISE** while simultaneously turning propeller shaft **COUNTERCLOCKWISE**.

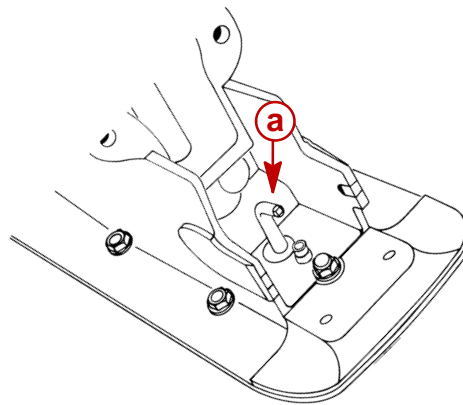

- a** - Drive Unit Shift Shaft

IMPORTANT: Be sure to install RH or LH drive unit on the appropriate transom assembly when making dual engine installations. The LH rotation drive unit can be identified by the decal on the back side of the upper drive shaft housing, which states:

“Alpha One - Counter Rotation”

4. Place gasket on bell housing.

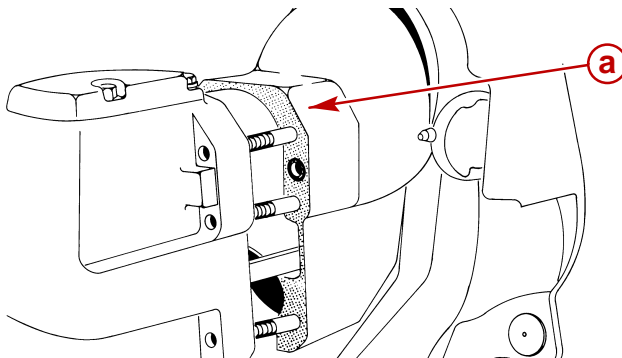

a - Gasket

70010

5. Install sterndrive unit as follows:

- a. Position trim cylinder straight back (over top of acceleration plate). Be careful not to scratch acceleration plate or trim cylinders.
- b. Guide U-joint shaft through gimbal bearing and into engine coupler while simultaneously guiding shift slide into drive shaft housing. Make sure shift slide remains upright and engaged with bell housing shift shaft lever.
- c. Remove Shift Slide Stabilizer Tool.
- d. Slide drive unit all the way into bell housing.

IMPORTANT: If drive unit will not slide all the way into bell housing, ensure that the shift shaft and couplers are positioned properly. Do not force drive unit into position.

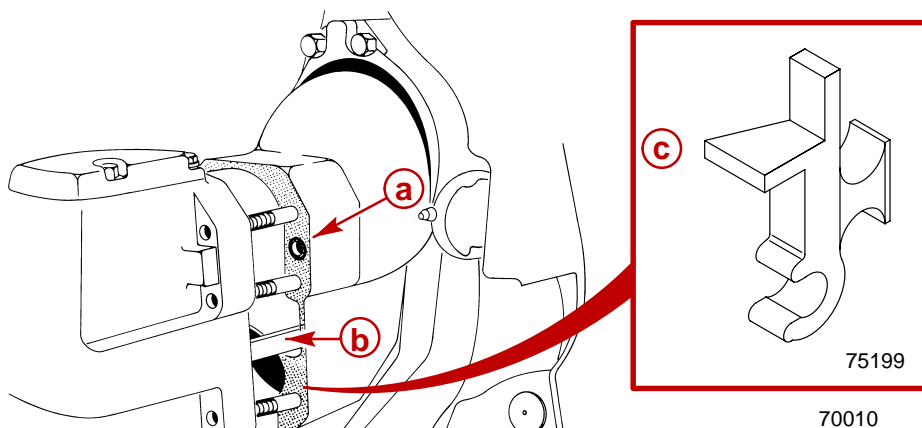

a - Gasket
b - Shift Slide
c - Shift Slide Stabilizer Tool

- e. If necessary, rotate propeller shaft **COUNTERCLOCKWISE** slightly to help align U-joint shaft splines with engine coupler splines. Then slide drive unit all the way into bell housing.
- f. Secure drive unit to bell housings using fasteners as shown. Torque the fasteners.

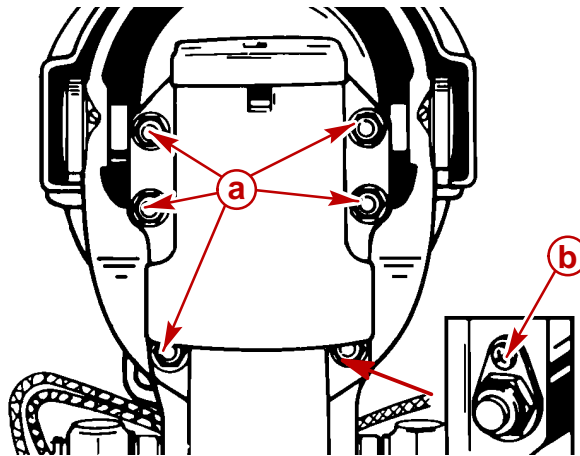

22062

- a** - Locknut And Flat Washers
- b** - Locknut And Continuity Circuit Washer (No Flat Washer At This Location)

Description	Nm	lb-in.	lb-ft
Fasteners	68		50

- 6. Return remote control shift lever to the NEUTRAL position.

Bravo Models

- 1. Lubricate O-ring seals.

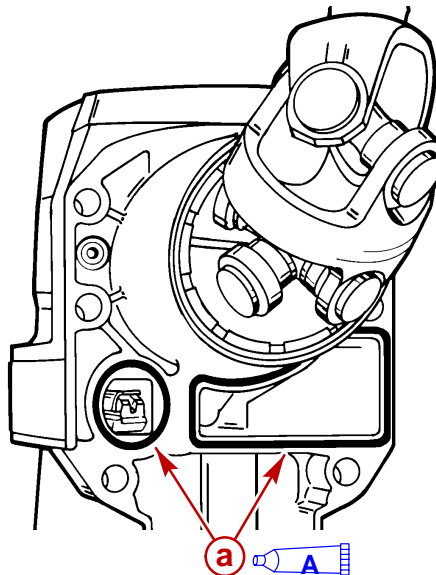

72183

- a** - O-ring Seals

Description	Where Used	Part Number
A 2-4-C Marine Lubricant With Teflon	O-ring Seals	92-825407A3

2. Pull out shift linkage as far as it moves. Jaws will open.

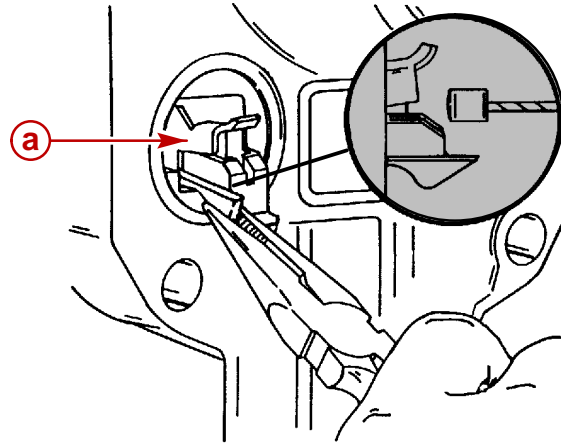

72460

a - Shift Linkage

IMPORTANT: As sterndrive is inserted into sterndrive unit, entry of the bell housing shift cable must be closely checked to make sure cable enters the jaws of shift linkage assembly in the sterndrive.

3. Place remote control in NEUTRAL position.

NOTE: As bell housing shift cable enters the shift linkage assembly, it pushes the assembly back into the sterndrive housing, and the jaw closes, securing the cable, as shown in steps "A", "B" and "C."

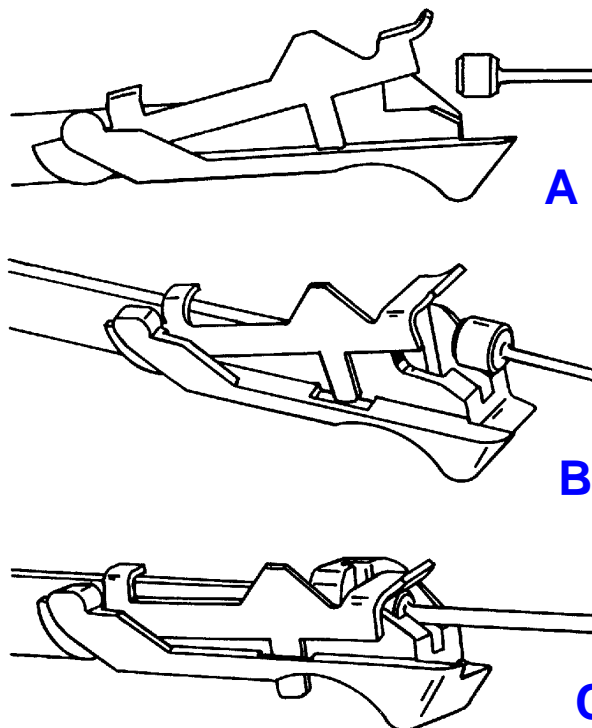

72467

IMPORTANT: If Bell Housing Shift Cable does not line up to properly enter jaws of shift linkage assembly, cable will have to be aligned manually.

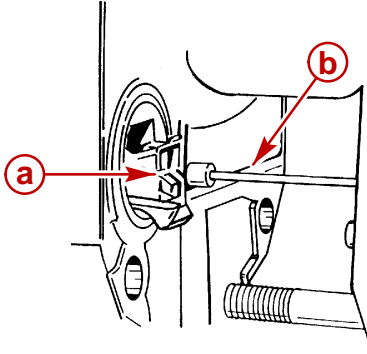

72457

- a** - Shift Linkage Assembly
- b** - Shift Cable

4. Place drive shaft housing in position on bell housing and install sterndrive unit, as follows:
 - a. Remove the nuts from the trim cylinders.
 - b. Position trim cylinders so they point straight backwards.
 - c. Position sterndrive unit so that universal joint shaft aligns with bell housing bore.
 - d. Guide U-joint shaft through bearing in gimbal housing and into engine coupler. Make sure that shift linkage jaws engage the bell housing shift cable assembly.
 - e. If necessary, rotate propeller shaft COUNTERCLOCKWISE slightly (using a propeller) to align U-joint shaft splines with splines in engine coupling, then slide sterndrive unit all the way into bell housing.
5. Secure sterndrive unit to bell housing with 5 flat washers and 6 locknuts and torque.

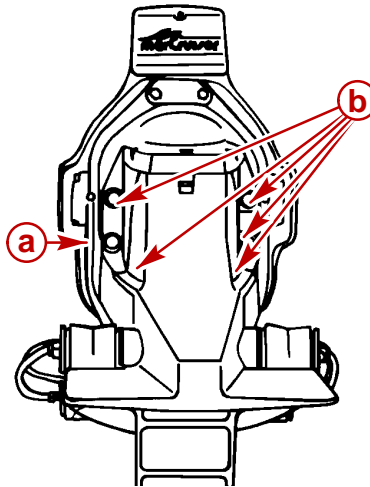

71244

- a** - Locknut Only
- b** - Locknuts And Flat Washers

Description	Nm	lb-in.	lb-ft
Sterndrive-To-Bell Housing	68		50

IMPORTANT: On Bravo One, Two and Three Models, the Trim-In Limit Insert must be properly positioned before installing the trim cylinder anchor pin in the following steps.

6. Ensure that the Trim-In Limit Insert is positioned as shown for the appropriate Bravo model.

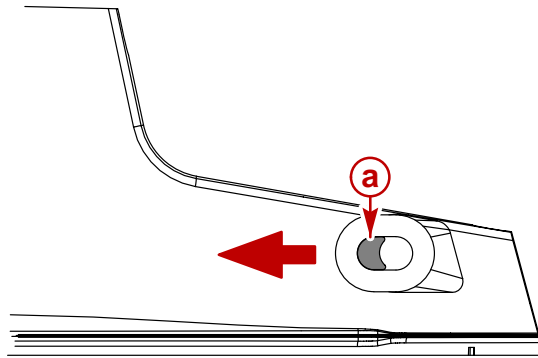

75157

Bravo One and Two (Positioned Forward)

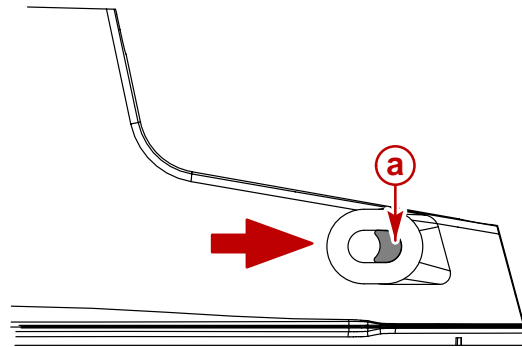

75158

Bravo Three (Positioned Aft)

a - Trim-In Limit Insert

IMPORTANT: The position of the Trim-In Limit Insert on the Bravo Three sterndrive unit should only be changed after the boat has been properly tested. Refer to Trim-In Limit Statement.

IMPORTANT: To aid in installing rubber bushings, use a water and soap solution. **DO NOT** use oil or grease.

All Models

1. Install trim cylinders on aft end of sterndrive unit with hardware as shown.
2. Install plastic caps and tighten hand tight only.

NOTE: Upon installation of hardware apply lubricant to all components except plastic caps.

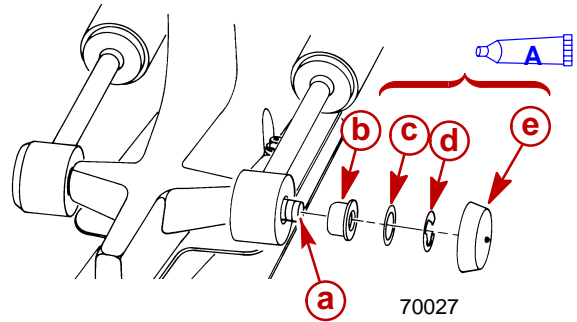
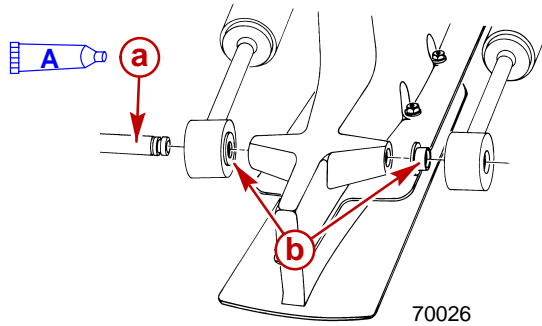

Alpha Models

- a** - Aft Anchor Pin
- b** - Bushings
- c** - Flat Washers
- d** - E-ring Clips
- e** - Plastic Caps

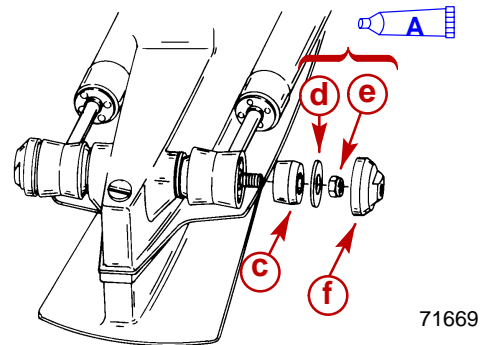
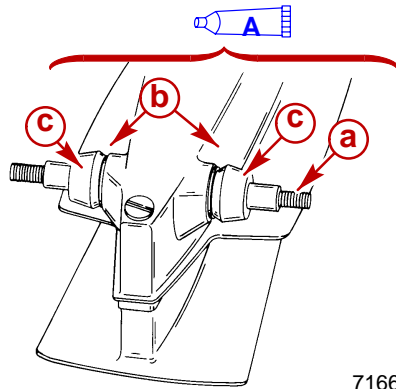

Bravo Models

- a** - Aft Anchor Pin
- b** - Large I.D. Flat Washers (2)
- c** - Rubber Bushings (4)
- d** - Small I.D. Flat Washers (2)
- e** - Locknuts (2)
- f** - Plastic Caps (2)

Description	Where Used	Part Number
A 2-4-C Marine Lubricant With Teflon	Trim Cylinder Hardware	92-825407A3

3. Position the drive unit serial number decal.

Speedometer Connection

Alpha Models

1. Raise drive to gain access to area between gimbal housing and sterndrive, immediately above the transom end of the anti-ventilation plate.
2. Align plastic slots on male and female portions and insert.
3. Push down to secure.

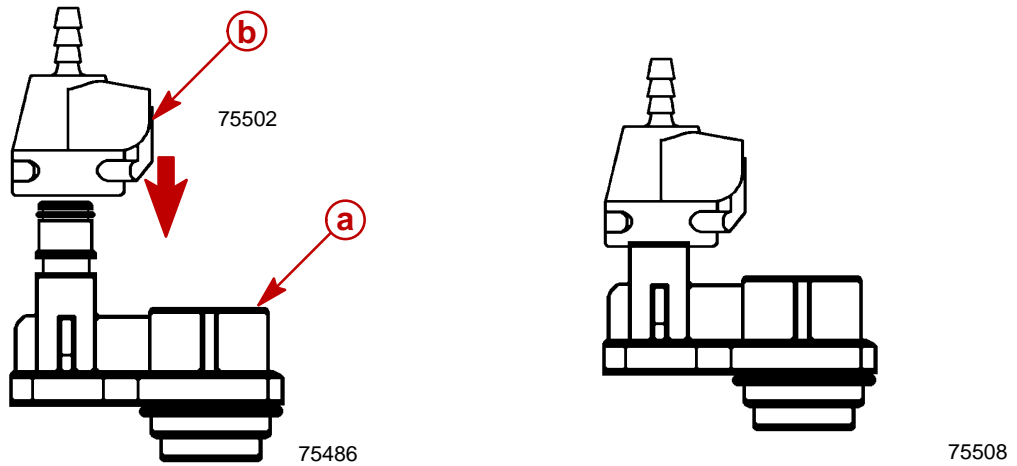

a - Male End Of Speedometer Tube Fitting
b - Female Portion

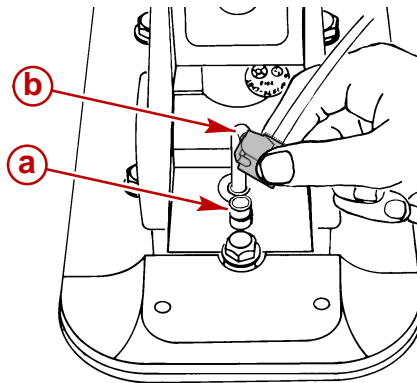

a - Tube Fitting, Male End
b - Topside Portion, Female End

Bravo Models

1. Raise sterndrive to gain access to area between gimbal housing and sterndrive, immediately atop the transom end of the anti-ventilation plate.
2. Insert speedometer tube fitting into opening on topside of anti-ventilation plate, in position shown.

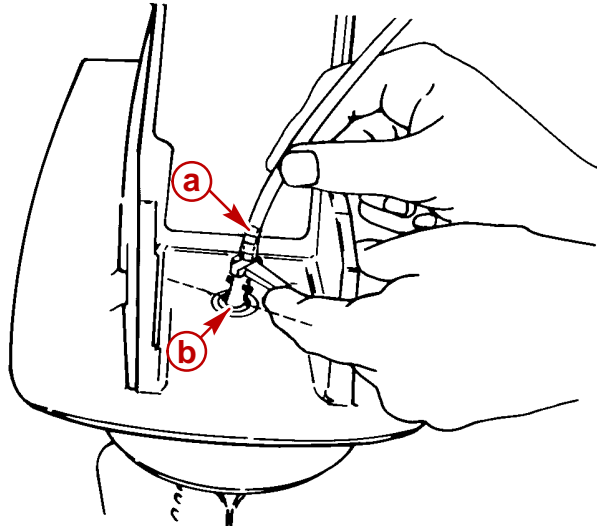

22025

- a** - Tube Fitting
- b** - Opening

3. With fitting fully seated, turn handle to left to a tightly seated position, as shown.

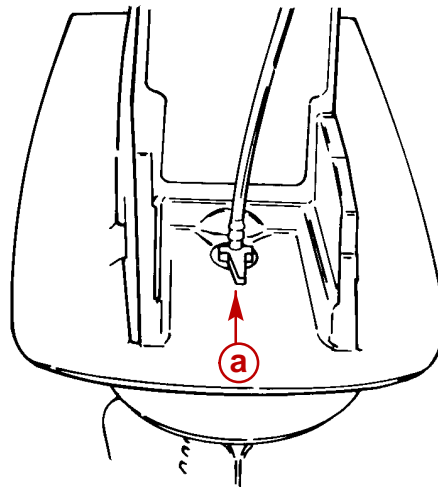

22025

- a** - Handle

Shift Cable Installation

Alpha Models - Drive Unit Installed

IMPORTANT: Shift cable adjustment for a right hand (RH) rotation drive unit is different than the procedure for adjusting a left hand (LH) rotation drive unit. Be sure to refer to the appropriate procedure when performing the following steps.

IMPORTANT: Drive unit must be installed.

IMPORTANT: DO NOT run engine.

1. Remove remote control shift cable and shift assist assembly (if installed).

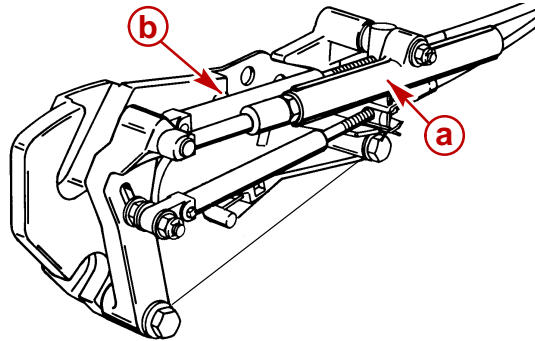

75414

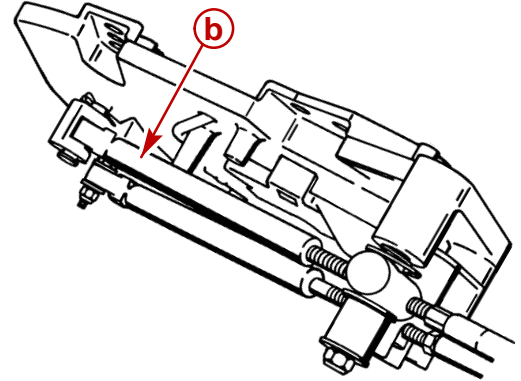

50310

With Shift Assist Assembly Without Shift Assist Assembly

- a** - Shift Assist Assembly
- b** - Remote Control Shift Cable

2. Ensure shift lever adjustable stud is at bottom of slot.

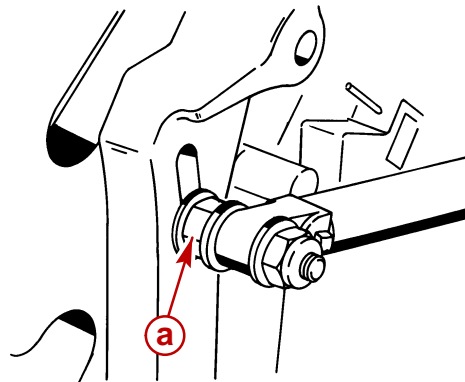

- a** - Adjustable Stud

50309

3. Shift remote control as stated in a. or b. following:
 - a. **Right Hand (RH) Rotation Drive Unit** - FORWARD gear, past detent, into WOT position.
 - b. **Left Hand (LH) Rotation Drive Unit** - REVERSE gear, past detent, into WOT position.

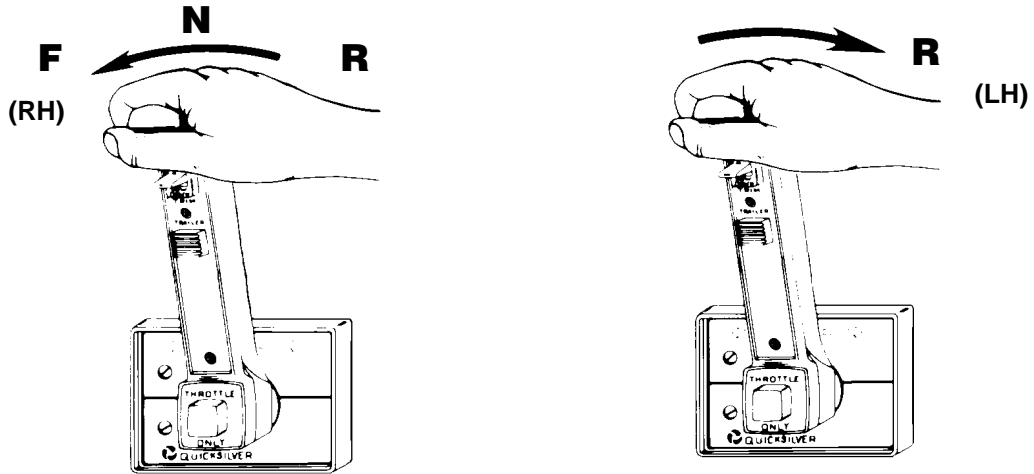

4. Place drive unit into gear by pushing in on drive unit shift cable while simultaneously rotating propeller shaft COUNTERCLOCKWISE until shaft stops. This will ensure full clutch engagement. Maintain a light pressure on the drive unit shift cable to hold it at the end of its travel (this removes all slack from the cable).

IMPORTANT: Do not use excessive force when holding pressure on the drive unit shift cable. Excessive force would be indicated by movement of the shift cutout switch.

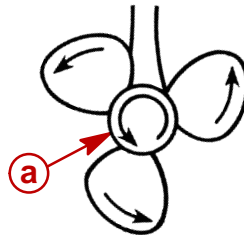

22266

a - Propeller Shaft - Rotate COUNTERCLOCKWISE

5. Lightly pull on remote control shift cable end guide (to remove slack from remote control and cable) and adjust brass barrel as necessary to align attaching points with shift lever clevis pin hole and stud. Be sure to maintain light pressure on drive unit shift cable.

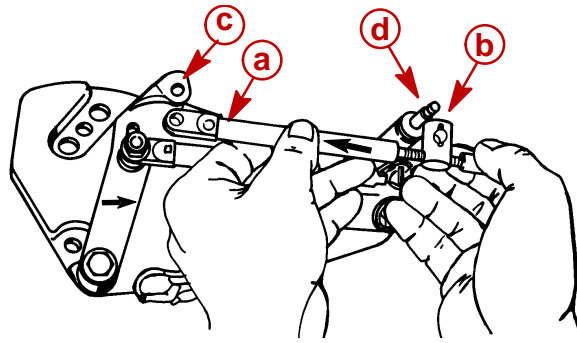

50309

- a** - End Guide
- b** - Brass Barrel
- c** - Shift Lever Clevis Pin Hole
- d** - Stud

6. Temporarily install remote control shift cable on stud and install clevis pin.

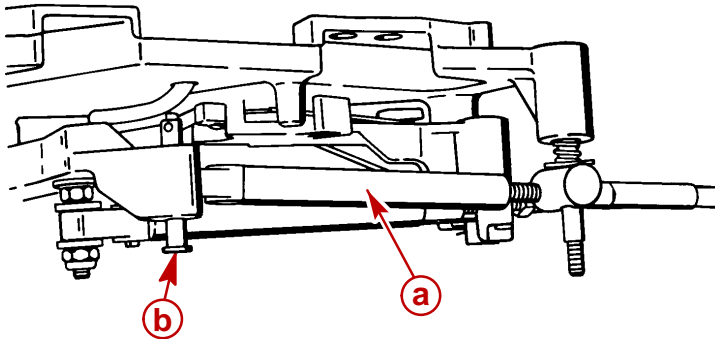

50308

- a** - Remote Control Shift Cable
- b** - Clevis Pin

7. Shift remote control as stated in a. or b. following:

- a. **Right Hand (RH) Rotation Drive Unit** - REVERSE gear, past detent, into WOT position.
- b. **Left Hand (LH) Rotation Drive Unit** - FORWARD gear, past detent, into WOT position.

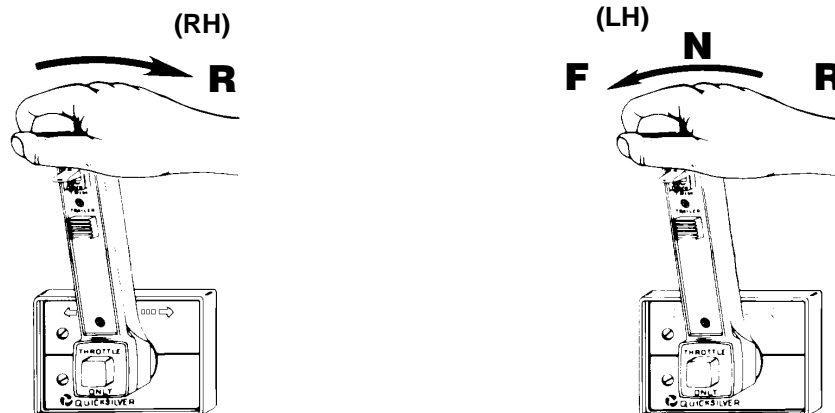

8. To ensure full clutch engagement, simultaneously rotate propeller shaft **CLOCKWISE** until shaft stops.

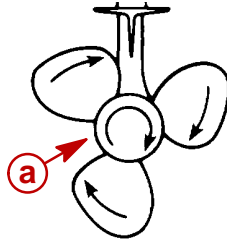

22267

a - Propeller Shaft - Rotate **CLOCKWISE**

9. Check shift cutout switch plunger position. Pin must be centered.

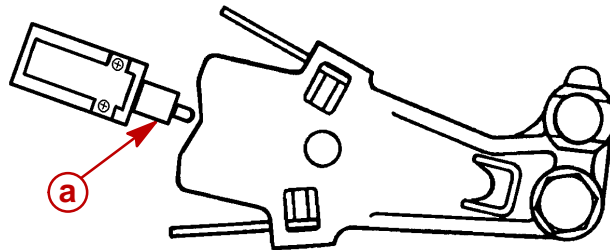

75435

a - Shift Cutout Switch Plunger Pin

10. If plunger pin is not centered:
 - a. Ensure adjustable stud is at bottom of slot in shift lever.
 - b. Check remote control for proper shift cable output [3 in. (76 mm) \pm 1/8 in. (3 mm)].
 - c. If a. and b. are correct, ensure drive unit shift cable is not crushed or kinked. (If drive unit shift cable is binding, the shift cutout switch plunger pin will move off center when shifting into and out of FORWARD and REVERSE.)

NOTE: If shift cable was damaged during installation, install new shift cable assembly in accordance with instructions contained in sterndrive service manual, then repeat shift cable adjustment procedure.

11. After remote control shift cable has been properly adjusted, reinstall cable and shift assist assembly (if applicable) and secure with hardware as shown. If shift assist assembly attaching points will not align, push in or pull out on end of shift assist assembly to install. Do not attempt to readjust shift cable.

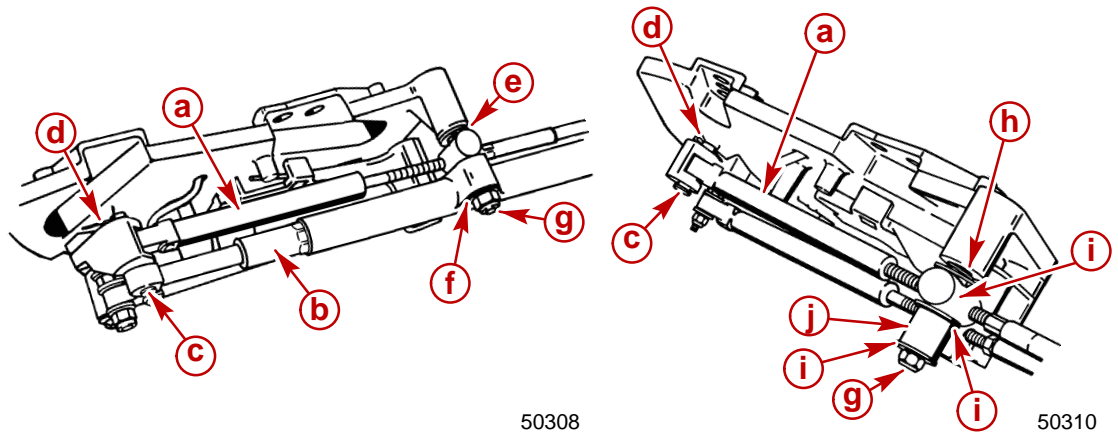

With Shift Assist Assembly

Without Shift Assist Assembly

- a** - Remote Control Shift Cable
- b** - Shift Assist Assembly
- c** - Clevis Pin
- d** - Cotter Pin (Spread Both Prongs)
- e** - Large I.D. Washer
- f** - Small I.D. Washer
- g** - Locknut (Tighten Until Contacts, Then Loosen 1/2 Turn)
- h** - Spring (Existing)
- i** - Washer (Existing)
- j** - Spacer

IMPORTANT: If an extra long remote control shift cable is used, there are a large number of bends in remote control shift cable or remote control has inadequate output travel, an additional adjustment may be necessary. Refer to step 12. or 13. as applicable.

12. Remote Control with Single Lever Shift/Throttle Control:

- a. **RIGHT HAND (RH) propeller rotation drive unit** - Shift remote control into REVERSE gear, WOT position while simultaneously rotating propeller shaft CLOCKWISE. Clutch should engage and cause propeller shaft to lock. If clutch does not engage, loosen adjustable stud on shift lever and move it up in slot until clutch engages with REVERSE gear. Retighten stud. Shift remote control several times and stop in REVERSE to recheck shift cutout switch position. Pin must be centered.
- b. **LEFT HAND (LH) propeller rotation drive unit** - Shift remote control into FORWARD gear, WOT position while simultaneously rotating propeller shaft CLOCKWISE. Clutch should engage and cause propeller shaft to lock. If clutch does not engage, loosen adjustable stud on shift lever and move it up in slot until clutch engages with FORWARD gear. Retighten stud. Shift remote control several times and stop in FORWARD to recheck shift cutout switch position. Pin must be centered.

13. Two Lever Remote Control with Separate Shift and Throttle Levers:

- a. **RIGHT HAND (RH) propeller rotation drive unit** - While turning propeller shaft CLOCKWISE, move remote control shift handle into full REVERSE position. Clutch should engage before shift lever comes to a stop. If clutch does not engage, loosen adjustable stud on shift lever and move it up in slot until clutch engages with REVERSE gear. Retighten stud. Shift remote control several times and stop in REVERSE to recheck shift cutout switch position. Pin must be centered.
- b. **LEFT HAND (LH) propeller rotation drive unit** - While turning propeller shaft CLOCKWISE, move remote control shift handle into full FORWARD position. Clutch should engage before shift lever comes to a stop. If clutch does not engage, loosen adjustable stud on shift lever and move it up in slot until clutch engages with FORWARD gear. Retighten stud. Shift remote control several times and stop in FORWARD to recheck shift cutout switch position. Pin must be centered.

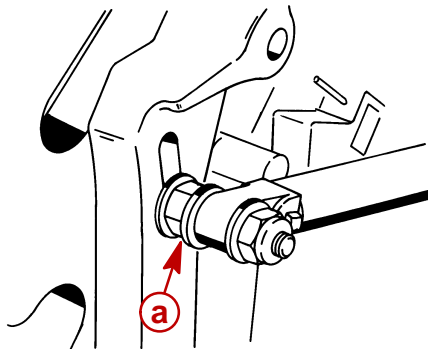

50309

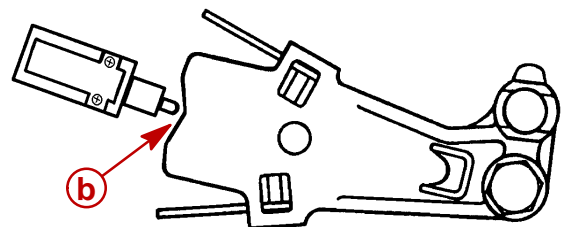

75435

- a - Adjustable Stud
- b - Shift Cutout Switch Plunger Pin

Troubleshooting Shift Problems

NOTE: The following information is provided to assist an installer in troubleshooting if hard shifting or chocking/racheting is encountered when shifting into FORWARD gear.

1. When installing the control box in the side panel of the boat, make sure that the cables have enough clearance to operate. This is necessary because the cables move up and down when the shift handle is moved. If the control box is mounted too far back toward any fiberglass structure, the cables will be interfered with; this will cause very hard shifting.

NOTE: The control box housing can be rotated in 30 degree increments to improve cable routing.

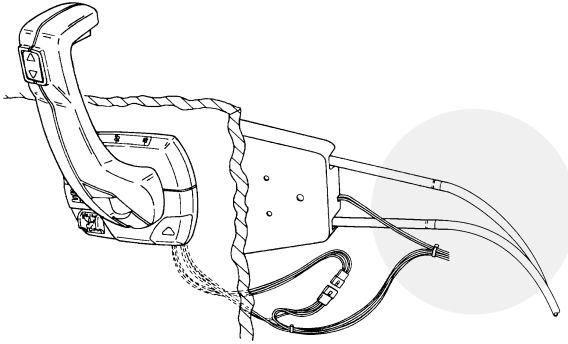

74688

Proper Cable Bend

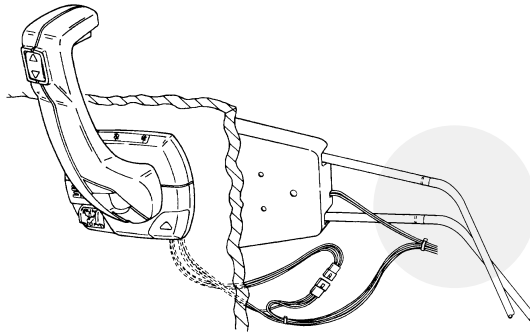

74689

Improper Cable Bend

2. Make sure that when the shift cable from the control box is led through the side gunnel of the hull, it does not have any extremely sharp bends in it as this will cause stiff shifting.

- Before installing the shift cable into the control box, extend the stainless rod eye end of the cable and grease it with 2-4-C Marine Lubricant with Teflon. Move it back and forth to allow even distribution of the grease.

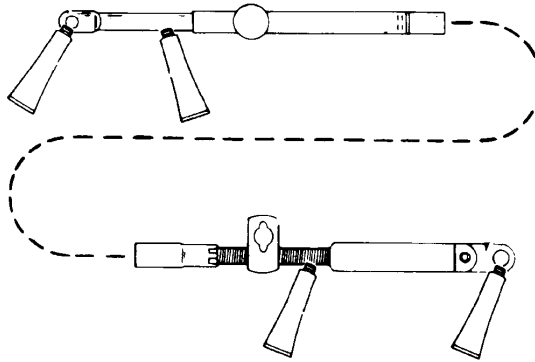

Description	Where Used	Part Number
2-4-C Marine Lubricant With Teflon	Shift Cable End	92-825407A3

- Do not strap or clamp the control cables to any other cables or rigid structure within 3 ft. (914 mm) of the control box.
- Be sure the cable is not permanently kinked.
- Make sure there is proper clearance for cable movement when the control box is installed in the side panel. The cables must have room to move up and down when the control handle is shifted into either FORWARD or REVERSE.
- Ensure that the engine was not set down on the intermediate shift cable during installation, as this will crush the inner cable tubing and cause improper and / or stiff shifting.
- DO NOT fasten the shift cable with straps or clamps to any other cable within 5 ft. (1.5 m) of the shift plate.
- DO NOT fasten the shift cable to the transom with any type of plastic clips or fasteners within 5 ft. (1.5 m) of the shift plate.
- DO NOT overtighten the throttle or shift cable attaching nuts at the engine end. Barrel and cable end must be free to rotate on the mounting stud.

NOTE: Lubricate attaching points with engine oil.

Description	Where Used	Part Number
SAE 30W Engine Oil	Shift Cable Pivot Points	Obtain Locally

11. Check the intermediate shift cable routing from the transom assembly to the shift plate as follows:
 - a. The cable should come through the transom, above the exhaust pipe and make a turn toward the starboard side of the boat between the exhaust pipe and the engine flywheel housing.
 - b. The cable should then be routed under the starboard rear engine mount and turn toward the transom.
 - c. The cable should then go up behind the power steering valve and loop over to the shift plate on the engine, where it is connected to the anchor points on the shift plate.

Following this routing will prevent the engine coupler from damaging the cable.

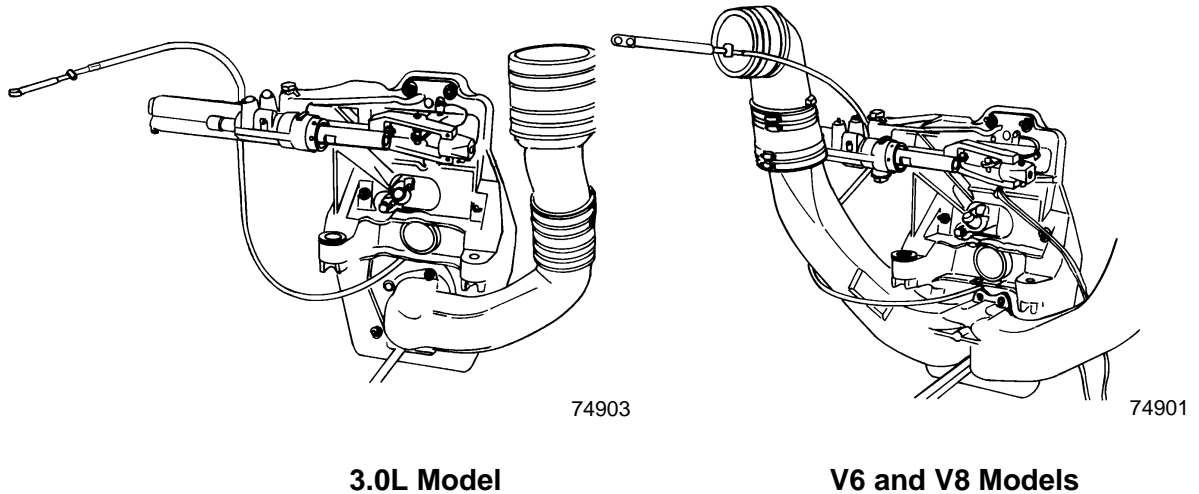

NOTE: A final check of the adjustments should be made with the boat in the water and engine running. If this cannot be done or is not done at your manufacturing facility, arrangement should be made with the dealer to do this as part of the pre-delivery inspection.

Predelivery Preparation

Once the power package installation is complete, the following final steps should be taken to prepare power package for delivery to the customer. It is the boat manufacturer's responsibility to perform these procedures, or to make arrangement with the dealer to have these procedures completed.

Power Steering Fluid

IMPORTANT: Use only specified lubricant.

⚠ CAUTION
DO NOT RUN POWER STEERING DRY or pump will be damaged.

1. Position sterndrive unit so that it is straight back.
2. Remove fill cap from power steering pump and check fluid level using dipstick. Add fluid as required.

NOTE: Be prepared to add fluid to pump when first starting engine.

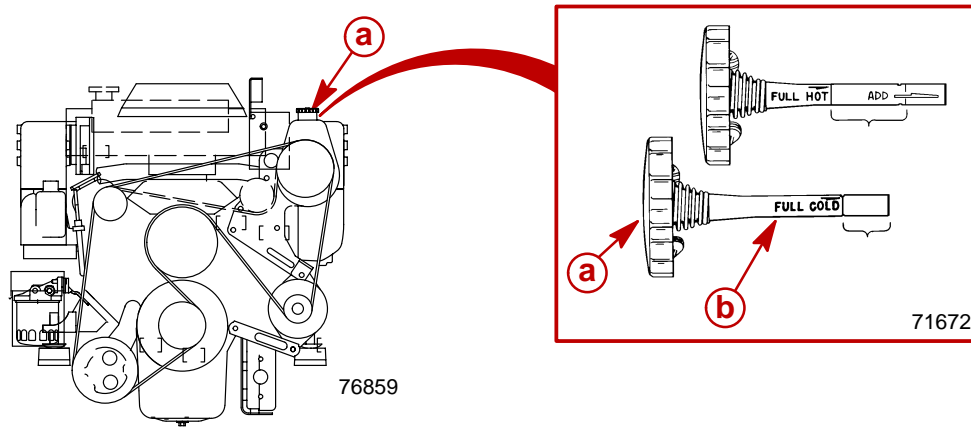

- a** - Fill Cap
- b** - Dipstick

Description	Where Used	Part Number
Power Trim and Steering Fluid	Power Steering Pump	92-90100A12
Dexron III - Automatic Transmission Fluid		Obtain Locally

Filling Coolant Recovery Bottle

1. Remove cap from coolant recovery reservoir and fill to FULL mark with coolant solution. Reinstall cap.
2. Recheck coolant level after first open-throttle boat test and add coolant, if necessary.
3. Maintain coolant level in coolant recovery reservoir between ADD and FULL marks with engine at normal operating temperature.

Power Trim Pump

1. Check oil level with sterndrive unit in the full DOWN/IN position.

IMPORTANT: Use only specified lubricant.

2. If not previously done, unscrew fill cap and **remove** cap plug from fill neck and **discard**. Install fill cap.

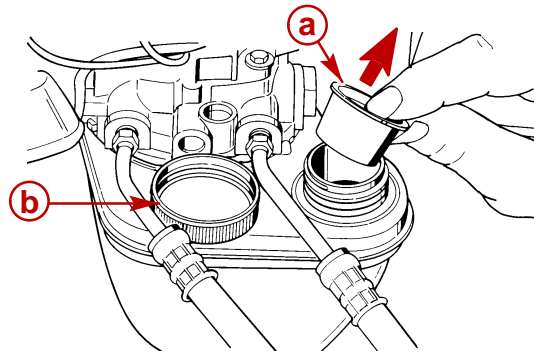

50630

- a** - Cap Plug
- b** - Fill Cap

3. Raise and lower sterndrive unit (to the full UP/OUT position) 6 to 10 times to purge air from system. Check oil level visually, (with drive unit in the full DOWN/IN position). Oil level should be maintained within the ADD and FILL or MINIMUM and MAXIMUM lines on the reservoir.

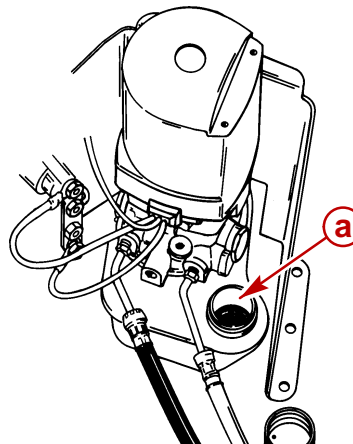

22031

- a** - Fill Neck

4. Check all trim line connection points for leaks. If fluid is visible at fittings, tighten fittings. Torque fittings.

Description	Nm	lb-in.	lb-ft
Fittings	14	125	

Trim Position Sender Adjustment

ANALOG GAUGES

1. Loosen both trim position sender retaining screws.

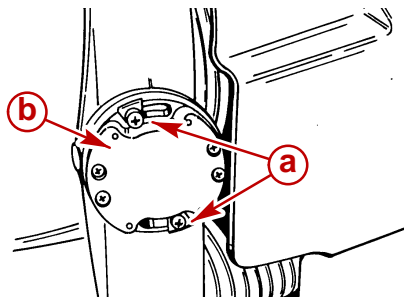

71220

- a** - Retaining Screws
- b** - Trim Position Sender

CAUTION

DO NOT start engine in the following step or damage to sterndrive unit and engine could result from lack of cooling water.

2. Turn ignition key to RUN position.
3. Trim sterndrive unit to the full DOWN/IN position.
4. Rotate trim position sender as required to show full DOWN/IN position on dashboard instrument as shown.

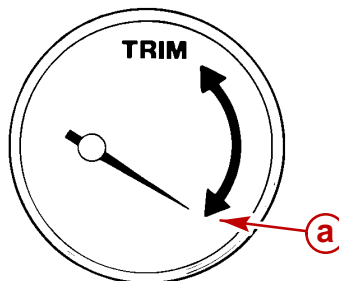

71671

- a** - Trim Gauge Needle

5. Tighten retaining screws and turn ignition key to the OFF position.

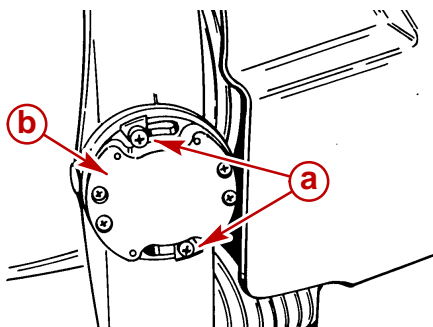

71220

- a** - Retaining Screws
- b** - Trim Position Sender

Propeller Selection

GENERAL INFORMATION

IMPORTANT: Installed propeller must allow engine to run at its specified maximum WOT rpm. Use an accurate service tachometer to verify engine operating rpm.

It is the responsibility of the boat manufacturer and/or the selling dealer to equip the power package with the correct propeller. Refer to Quicksilver publication - *Everything You Need To Know About Propellers P/N 90-8614492*. Specified engine WOT and operating rpm range are listed in the *Mercury MerCruiser Operation, Maintenance and Warranty Manual* attached to the engine.

If full throttle operation is below the recommended range, the propeller must be changed to prevent loss of performance and possible engine damage. On the other hand, operating an engine above the recommended operating rpm range will cause higher than normal wear and/or damage.

After initial propeller selection, the following common problems may require that the propeller be changed to a lower pitch:

- Warmer weather and greater humidity cause an rpm loss.
- Operating in a higher elevation causes an rpm loss.
- Operating with increased load (additional passengers, pulling skiers, etc.).

For better acceleration, such as is needed for water skiing, use the next lower pitch propeller. However, do not operate at full throttle when using the lower pitch propeller but not pulling skiers.

Because of the many variables of boat design, only testing will determine the best propeller for a particular application. Available propellers are listed in the *Mercury Precision Parts / Quicksilver Accessories Guide*.

See BOAT IN THE WATER TESTS, Maximum RPM Test at the back of this manual.

ENGINE REV-LIMITER

IMPORTANT: The engines listed in the following chart are equipped with a rpm rev-limiter that is set to an upper (or limited) rpm amount. This limit is slightly above the normal operating range of the engine and is designed to help prevent damage from excessive engine rpm. When the engine reaches the rev-limit rpm, the horn will sound. Once the rpm drop into the recommended operating rpm range, normal engine operation resumes.

Engine Rev-Limiter		
Model	Engine Recommended Operating RPM Range	Rev-Limit RPM Setting
3.0L	4400-4800	Not Applicable
4.3L	4400-4800	4950
5.0L	4400-4800	4950
5.7L	4400-4800	4950

Propeller Installation

⚠ WARNING

Be sure that remote control is in **NEUTRAL** position and ignition key is removed from switch prior to installing propeller.

⚠ WARNING

Place a block of wood between the anti-ventilation plate and propeller to protect hands from propeller blades and to prevent propeller from turning when tightening propeller nut.

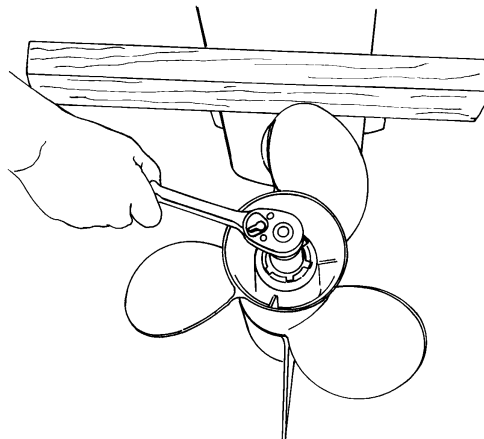

71560

- To aid in future removal of the propeller, liberally coat propeller shaft splines with one of the following lubricants:

Description	Where Used	Part Number
2-4-C Marine Lubricant With Teflon	Propeller Shaft Splines	92-825407A3
Special Lubricant 101		92-13872A1

IMPORTANT: Installation is correct when at least 2 threads of propeller shaft are exposed through propeller nut after torquing it.

ALPHA MODELS

- Install propeller with attaching hardware as shown. Torque the nut, then continue to tighten until 3 tabs on the tab washer align with grooves on spline washer. Bend the 3 tabs down into grooves.

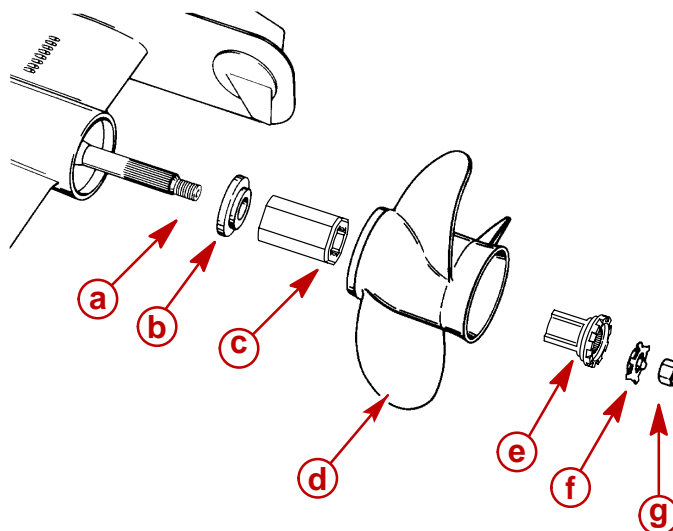

76910

- a** - Propeller Shaft Splines
- b** - Forward Thrust Hub
- c** - Flo-Torque II Drive Hub
- d** - Propeller
- e** - Drive Sleeve Adapter
- f** - Locking Tab Washer
- g** - Propeller Nut

Description	Nm	lb-in.	lb-ft
Propeller Nut	75		55
	Then align tabs with grooves.		

BRAVO ONE AND TWO

IMPORTANT: Correct rotation propeller MUST match direction of rotation of propeller shaft.

1. Install propeller with attaching hardware as shown.
2. Apply lubricant on splines of propeller shaft.
3. Torque the nut, then continue to tighten until 3 tabs on the tab washer align with grooves on spline washer. Bend the 3 tabs down into grooves.

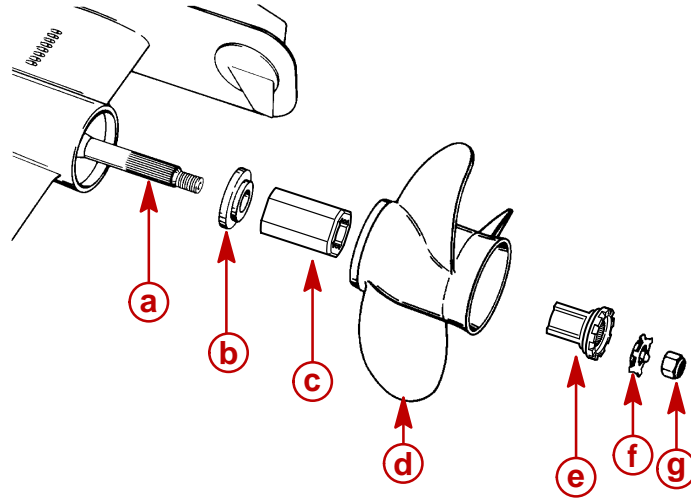

76910

Bravo One

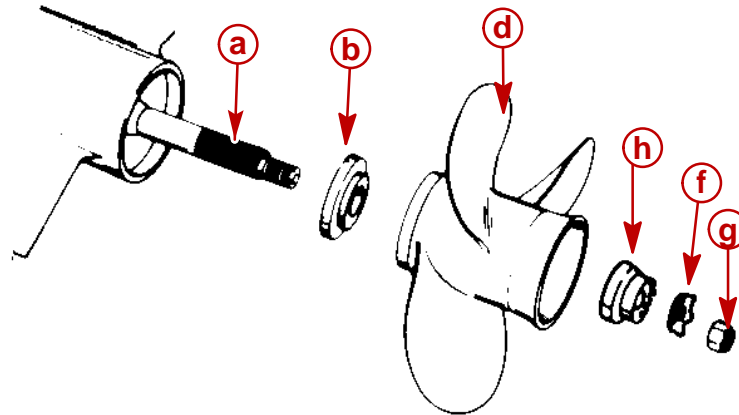

70561

Bravo Two

- a** - Propeller Shaft Splines
- b** - Forward Thrust Hub
- c** - Flo-Torque Drive Hub
- d** - Propeller
- e** - Drive Sleeve Adapter
- f** - Tab Washer
- g** - Locknut
- h** - Continuity/Spline Washer

Description	Nm	lb-in.	lb-ft
Locknut	75		55
	Then align tabs with grooves.		

BRAVO THREE

IMPORTANT: Correct rotation propeller MUST match direction of rotation of propeller shaft.

1. Slide forward thrust hub onto propeller shaft, with tapered side toward propeller hub.
2. Align splines and place front propeller on propeller shaft.
3. Install front propeller locknut and torque.

Description	Nm	lb-in.	lb-ft
Front Propeller Locknut	136		100

4. Slide aft thrust hub onto propeller shaft with tapered side toward propeller hub.
5. Align splines and install aft propeller.
6. Install propeller locknut and torque.

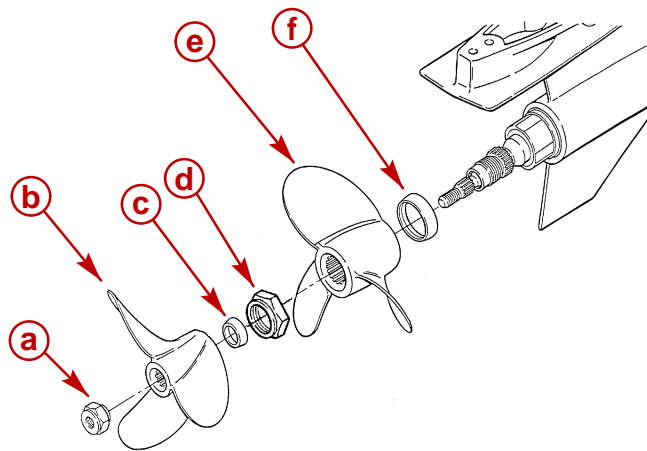

77107

Bravo Three

- a** - Rear Propeller Locknut
- b** - Rear Propeller
- c** - Rear Propeller Thrust Hub
- d** - Front Propeller Locknut
- e** - Front Propeller
- f** - Front Propeller Thrust Hub

Description	Nm	lb-in.	lb-ft
Rear Propeller Locknut	81		60

Battery

IMPORTANT: Boating industry standards (BIA, ABYC, etc.), federal standards and Coast Guard regulations must be adhered to when installing the battery. Be sure battery cable installation meets the pull test requirements and that positive battery terminal is properly insulated in accordance with regulations.

IMPORTANT: It is recommended (required in some states) that battery be installed in an enclosed case. Refer to regulations for your area.

IMPORTANT: Engine electrical system is negative (–) ground.

1. Select a battery that meets all of the following specifications:

- 12-volt marine type.
- Tapered post connectors or side terminal connectors.

IMPORTANT: DO NOT use a battery with wing nut connectors.

- Battery capacity rating of at least:

Engine (Cyl./Type)	cid (l)	Minimum Required Cranking Battery Size
4 In-Line	181 (3.0)	375 cca/475 mca/90 Ah
V6 Carb	262 (4.3)	
V8 Carb	305 (5.0)	
V8 Carb	350 (5.7)	

BATTERY CABLES

1. Select proper size positive (+) and negative (–) battery cables, using chart. Battery should be located as close to engine as possible.

IMPORTANT: Terminals must be soldered to cable ends to ensure good electrical contact. Use electrical grade (resin flux) solder only. DO NOT use acid flux solder, as it may cause corrosion and a subsequent failure.

Cable Length	Cable Gauge
Up to 3-1/2 ft. (1.1 m)	4 (25 mm ²)
3-1/2 - 6 ft. (1.1-1.8 m)	2 (35 mm ²)
6 - 7-1/2 ft. (1.8-2.3 m)	1 (50 mm ²)
7-1/2 - 9-1/2 ft. (2.3-2.9 m)	0 (50 mm ²)
9-1/2 - 12 ft. (2.9-3.7 m)	00 (70 mm ²)
12 - 15 ft. (3.7-4.6 m)	000 (95 mm ²)
15 - 19 ft. (4.6-5.8 m)	0000 (120 mm ²)

BATTERY CONNECTION

IMPORTANT: Engine electrical system is negative (-) ground.

1. Connect engine positive (+) battery cable (usually RED) to positive (+) battery terminal.
2. Connect engine negative (-) battery cable (usually BLACK) to negative (-) battery terminal.
3. Connect Power Trim pump BLACK (-) battery cable to negative (-) battery terminal and trim pump RED (+) battery cable to positive (+) battery terminal.
4. Make sure that all battery terminal connections are tight. Then spray terminals with a battery connection sealant to help retard corrosion.

Test Running Engine

⚠ WARNING

Avoid Injury: If engine is to be tested with the boat out of the water, the propeller must be removed to avoid injury.

⚠ CAUTION

Overheating from insufficient cooling water will cause engine and drive damage. Ensure that there is sufficient water always available at the water inlet holes during operation.

BOAT OUT OF THE WATER

For engine operation tests with the boat out of the water:

IMPORTANT: If using a flushing attachment over the water inlet holes and a water hose as shown, do not use full water source pressure.

1. Install a flushing attachment over the sterndrive water inlet holes.
2. Connect a hose between the flushing attachment and a water source.
3. Open the water source about 1/2 maximum. DO NOT use full water pressure.

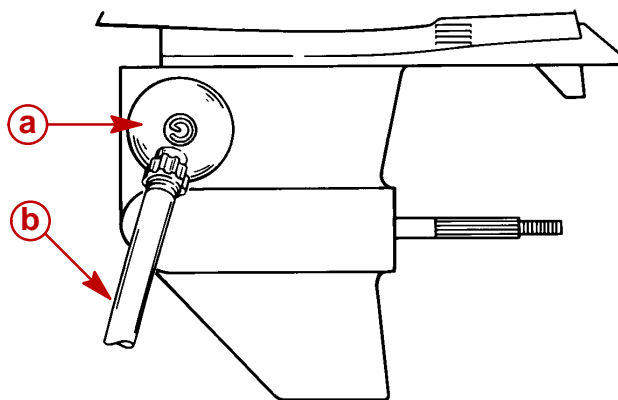

- a** - Flushing Attachment
b - Water Hose

70564

IMPORTANT: Engines with the sterndrive water inlet blocked off at the gimbal housing and using a through the hull water inlet, need a supply of cooling water available to both the sterndrive unit and to the engine during operation.

4. **On Engines With Through The Hull Water Inlet:** Supply sufficient cooling water to the engine.
5. Proceed to Testing.

BOAT IN THE WATER

For engine operation tests with the boat in the water:

IMPORTANT: If using a test tank the water level must be above the water inlet holes on the sterndrive unit or the through the hull pickup.

1. Ensure that the water level is above the water inlet holes on the sterndrive or the through the hull pickup.

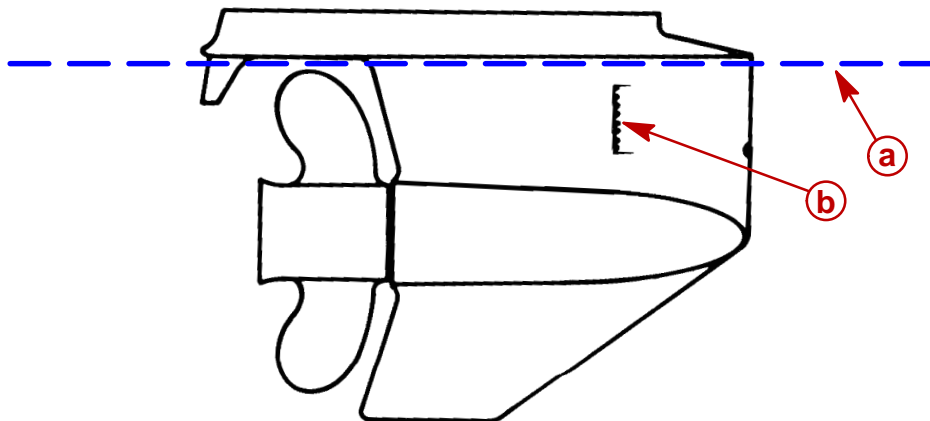

70099

Sterndrive Water Inlet (Through The Hull Similar)

- a** - Minimum Water Level
- b** - Water Inlet Holes

2. Proceed to Testing.

TESTING

⚠ WARNING

Do not leave helm unattended when making test with boat in the water.

1. Ensure that cooling system drain plugs, petcocks and hoses are installed and tight.

NOTE: Refer to appropriate Mercury MerCruiser Operation, Maintenance and Warranty Manual for operating specifications. Refer to appropriate Mercury MerCruiser Service Manual for fluid capacity information.

2. Check crankcase oil level.

IMPORTANT: Oil level in monitor will rise and lower during drive operation. Always check oil level when drive is cool and engine is shut down.

3. Check sterndrive unit oil level in the monitor.
4. Check drive belt tension.
5. Test Audio Warning System in accordance with instructions on instrumentation panel decal.
6. Supply water to the engine either by putting boat in the water or by using the correct flush device.

⚠ WARNING

If engine is to be tested with boat out of water, the propeller must be removed to avoid injury.

IMPORTANT: If using a test tank, ensure water level is above water intake holes.

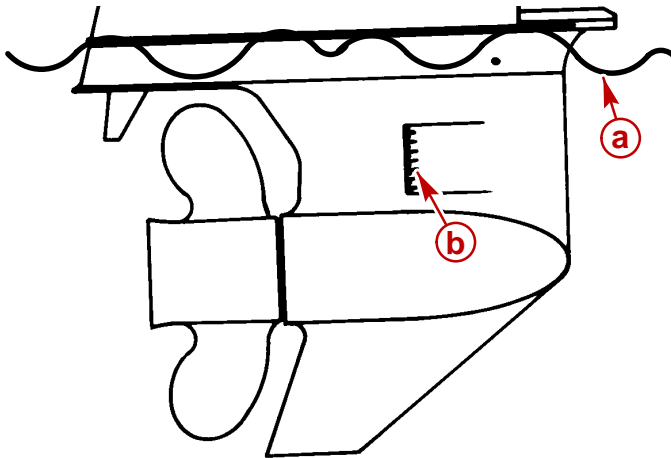

70082

- a - Minimum Water Level
- b - Water Intake Holes

⚠ CAUTION

If using flush test device, install over water intake holes and connect a water hose as shown. Do not use full water tap pressure. Also, do not run engine above 1500 rpm, as suction created could cause water hose to collapse causing water supply to be cut off.

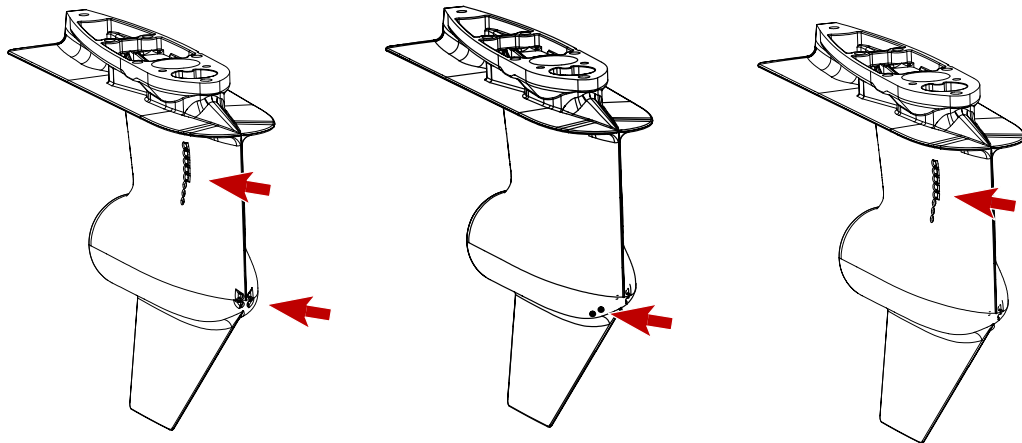

77899

Dual Water Pickup

Low Water Pickup

Side Pickup

7. Start engine and run at idle rpm until water temperature is normal.
8. Watch all gauges for normal readings.
9. Turn steering wheel RIGHT/STARBOARD, then LEFT/PORT, and ensure drive unit turns the correct way.
10. Inspect engine compartment for water, oil, fuel and exhaust leaks.
11. Turn steering wheel PORT until it stops and continue to apply pressure. If pump lugs (engine rpm drops and/or power steering pump tone changes):
 - a. Check for an obstruction between gimbal ring and gimbal housing and all moving steering components.
 - b. Check that steering lever is not contacting cutout in transom. If contact is being made, modify cutout.
12. Turn steering wheel STARBOARD until it stops and continue to apply pressure. If pump lugs (engine rpm drops and/or power steering pump tone changes):
 - a. Check same items as a. and b. above.
 - b. Check steering cable end dimension with cable FULLY EXTENDED.
13. Check power steering fluid level.
 - a. Turn off engine.
 - b. Remove cap/dipstick from power steering pump. Check fluid level and add if necessary.

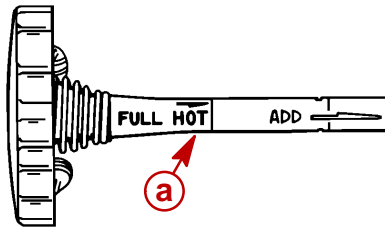

a - Dipstick (Full When Hot Line)

22023

Boat In The Water Tests

ENGINE IDLE SPEED - 3.0L MODELS

WARNING

DO NOT leave helm unattended while performing idle speed adjustment. Boat **MUST BE** moving forward (not tied to the dock) when setting idle speed.

1. Disconnect throttle cable from carburetor.
2. Start engine and place remote control lever in forward gear, idle position.
3. Adjust idle speed adjustment screw to obtain 700 rpm.
4. Stop engine. Readjust cable barrel and reinstall throttle cable.

ENGINE IDLE SPEED - V6 AND V8 MODELS

CAUTION

Avoid engine damage. Ensure that cooling water is supplied to the engine if it will be run with boat out of the water. See instructions in the Operation, Maintenance and Warranty Manual entitled "Flushing Cooling System," for instructions on connecting flush device.

The engines covered in this manual should idle at rpm (as specified in Operation, Maintenance and Warranty Manual) with engine at normal operating temperature. If idle speed is incorrect, proceed as follows:

1. Disconnect the throttle cable from carburetor.
2. Connect a shop tachometer to engine.

IMPORTANT: In order to properly set idle speed, the ignition module MUST BE locked in the Base Timing Mode. This is necessary because of the Idle Speed Control feature that exists in the ignition module. This must be done before the key switch is turned to the on or start position.

3. Using a jumper wire, connect the ignition system Timing Lead (PUR/WHT wire) to a good engine ground (-). This locks the ignition module into the Base Timing Mode. Refer to "Engine Wiring Harness" diagram in this manual.
4. Start engine and place the remote control lever in neutral gear, idle position.
5. Adjust idle speed to 650 rpm.
6. Stop engine. Readjust cable barrel and reinstall the throttle.

IMPORTANT: Throttle cable barrel must be adjusted properly.

IMPORTANT: Be sure to disconnect the jumper wire from the ignition system test lead before attempting to resume normal operations. If the jumper wire is left in place, the ignition module will operate in the Base Timing Mode. This means that the additional timing advance features would not be functioning.

7. Remove the jumper wire from the timing lead.

WIDE-OPEN-THROTTLE TEST

IMPORTANT: To run engine at full throttle before the break-in period is complete, follow this procedure.

1. Start engine and run at idle rpm until normal operating temperature is reached.
2. Run boat up on plane.
3. Advance engine rpm (in 200 rpm increments) until engine reaches its maximum rated rpm.
4. To test if the correct propeller has been installed, operate boat (with normal load on board) at WOT and check rpm with an accurate tachometer. Engine rpm should be near top of the specified range so that, under a heavy load, engine speed will not fall below specifications. If engine speed is too high, replace propeller with a higher pitch propeller. Normally a 1 inch propeller pitch change causes an rpm change of 150 rpm.
5. Shut off engine.
6. Check coolant level and add coolant if necessary.

TRIM TAB ADJUSTMENT (3.0L MODELS ONLY)

IMPORTANT: If power package is equipped with Power Steering, set trim tab so trailing edge is straight back. No adjustment is needed.

Models with Manual Steering: Operate boat at normal cruising speed, trimmed to desired position. Turn steering wheel left and right, noting in which direction the wheel turns more easily.

With engine OFF and boat at rest, remove plug from drive shaft housing and loosen attaching screw.

- A. If boat turns more easily to left, move trailing edge of trim tab to the left.
- B. If boat turns more easily to the right, move trailing edge of trim tab to the right.

Tighten attaching screw securely and install plug. Operate boat to check setting. Readjust trim tab if needed.

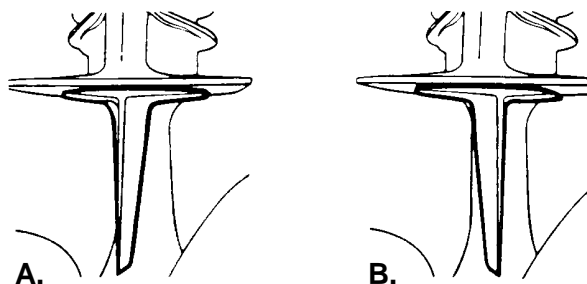

CHECKING SHIFT OPERATION

With sterndrive unit installed and engine running, ensure that drive unit shifts properly, as explained following:

1. Shift into FORWARD and REVERSE gear, making sure that clutch engages before engine begins to accelerate.
2. Accelerate engine while in FORWARD and REVERSE gear to ensure that engine does not stop.
3. Check that shift cutout switch plunger pin is centered in notch of shift cutout lever with drive unit in FORWARD and REVERSE gear.

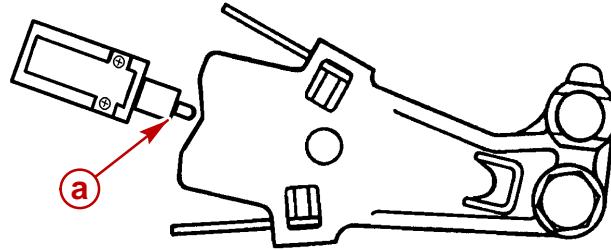

75435

a - Cutout Switch Plunger Pin

4. If the proper results are not achieved in the previous steps, shift cables must be readjusted.
5. Shifting from FORWARD and REVERSE to NEUTRAL: ensure drive unit is in NEUTRAL before remote control shift lever comes to the NEUTRAL detent position. Perform this check using various shifting rates to ensure that the drive unit shifts the same whether shifting fast or slow.

Cold Weather and Extended Storage

⚠ CAUTION

Sterndrive unit should be stored in full DOWN position. Universal Joint bellows may develop a “set” if unit is stored in raised position and may fail when unit is returned to service.

IMPORTANT: Mercury MerCruiser recommends that propylene glycol antifreeze (a nontoxic and environmentally safe) antifreeze be used in the seawater section of the cooling system for cold weather or extended storage. Make sure that the propylene glycol antifreeze contains a rust inhibitor and is recommended for use in marine engines. Be certain to follow the propylene glycol manufacturer’s recommendations.

⚠ CAUTION

Seawater section of cooling system **MUST BE COMPLETELY** drained for winter storage, or immediately after cold weather use, if the possibility of freezing temperatures exist. Failure to comply may result in trapped water causing freeze and/or corrosion damage to engine. Damage caused by freezing is **NOT** covered by the Mercury MerCruiser Limited Warranty.

Draining Instructions

⚠ CAUTION

Ensure that boat is out of the water or seacock is closed and bilge pump is operating before beginning procedure. Excess water in bilge can damage engine or cause boat to sink.

⚠ CAUTION

Do not operate engine with drain system open. Excess water in bilge can damage engine or cause boat to sink.

IMPORTANT: Boat must be as level as possible to ensure complete draining of cooling system.

Your power package is equipped with one of three drain systems. Refer to Identification on the following page to determine which instructions apply to your power package.

The power package should be drained before flushing or prior to extended or cold weather storage.

IMPORTANT: The boat must not be operating at any point during this procedure.

3.0L Single Point Drain

⚠ CAUTION

Ensure bilge pump is operating before beginning procedures. Excess water in bilge can damage engine or cause boat to sink.

⚠ CAUTION

Allow engine to cool down before disconnecting blue drain hoses. Engine water temperature can exceed 160° F (71° C).

⚠ CAUTION

Do not operate engine with blue drain hoses disconnected. Hot water can discharge violently.

IMPORTANT: Do NOT start or operate engine at any point in this procedure.

1. Turn on bilge pump.
2. Push quick connect fitting release buttons and remove blue drain hoses from the bracket.

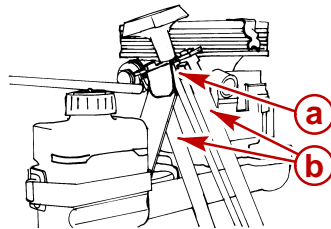

76242

- a** - Quick Connect Fitting Release button
- b** - Blue Drain Hoses

3. Pull T-handle until the hose guide is in contact with the quick connect fittings.

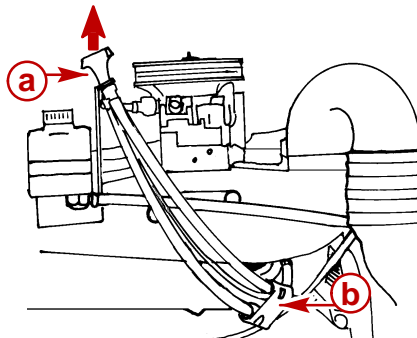

76243

- a** - T-Handle
- b** - Hose Guide

4. Push down on T-handle to force the blue drain hoses below their connection points to the block.

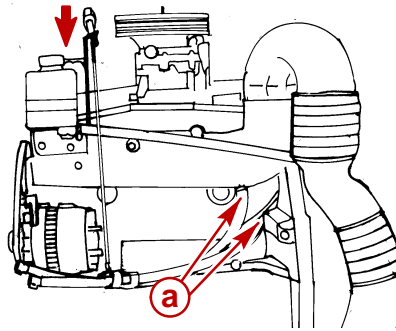

76244

a - Connection Points

5. Ensure water is draining from both blue drain hoses. If water is not draining from one or both blue drain hoses, go to “Clearing Clogged Blue Drain Hoses.”
6. Leave blue drain hoses disconnected until all water has drained from engine.
7. Pull T-handle until the quick connect fittings “a” on the blue drain hoses are within reach.

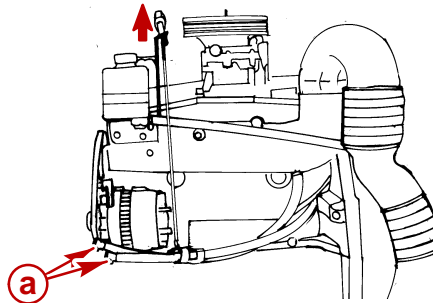

76244

a - Quick Connect Fittings

8. Install quick connect fittings on the bracket. Pull on the blue drain hoses to ensure they are firmly connected.
9. Push down on handle and move into the slot on the bracket.
10. Turn off bilge pump.

IMPORTANT: The next time the engine is started, visually inspect that the blue drain hoses are connected and not leaking.

CLEARING CLOGGED BLUE DRAIN HOSES

Boat In Water

⚠ CAUTION

Allow engine to cool down before disconnecting blue drain hoses. Engine water temperature can exceed 160° F (71° C).

⚠ CAUTION

Ensure bilge pump is operating before beginning procedures. Excess water in bilge can damage engine or cause boat to sink.

1. Reconnect the UNCLOGGED blue drain hose to the bracket.
2. Ensure CLOGGED blue drain hose is in correct position below its connection point to the block.
3. Turn on bilge pump.
4. Start engine. Allow it to run at idle until the obstruction is cleared from the hose or for approximately 1 minute, whichever occurs first.
5. Check for water draining from the blue drain hose. If after 1 minute of idling, the blue drain hose is still clogged, go to Step 6. If water is draining, shut off engine and return to Step 3 of "3.0L Single Point Drain."
6. Shut off engine.
7. Attach the female end of the water hose adapter fitting to a water supply.

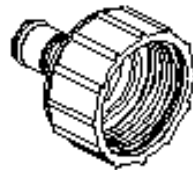

76287

8. Attach the CLOGGED blue drain hose to the male end on the water hose adapter fitting.
9. Fully open the water supply and allow it to run for 1 minute.
10. Turn off the water supply.
11. Disconnect the water hose adapter from the blue drain hose and the water hose.
12. Push down on T-handle to force the blue drain hoses down below their connection points to the block.
13. Check for water draining from the blue drain hose. If blue drain hose is still clogged, shut off the bilge pump and reattach the blue drain hoses following Steps 7 - 9 in "3.0L Single Point Drain." The unit will need to be serviced by an authorized Mercury MerCruiser dealer. If water is draining, return to Step 4 of "3.0L Single Point Drain."

BOAT OUT OF WATER

Engine Not Running

1. Attach the water hose adapter fitting to a water supply.
2. Attach the clogged blue drain hose to the male end on the water hose adapter fitting.
3. Turn on bilge pump.
4. Fully open the water supply and allow it to run for 1 minute.
5. Turn off the water supply.

6. Disconnect the water hose adapter from the blue drain hose and the water hose.
7. Check for water draining from the blue drain hose. If water is draining, return to Step 3 of "3.0L Single Point Drain." If water is not draining, go to "Boat Out of Water - Engine Running." If you cannot perform the engine running procedure, the unit will need to be serviced by an authorized Mercury MerCruiser dealer.

Engine Running

1. Attach UNCLOGGED blue drain hose to the bracket, leaving the CLOGGED blue drain hose disconnected.
2. Install flushing attachment over water pickup holes in gear housing as shown.

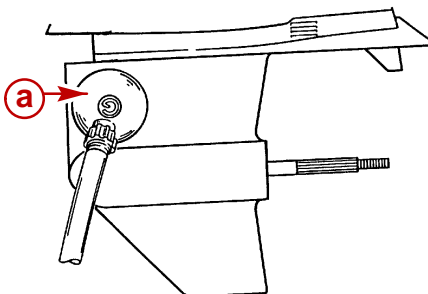

72693

a - Flushing Attachment

3. Attach a hose between the flushing attachment and a water supply.
4. Partially open water supply (approximately 1/2 maximum capacity). DO NOT use full water pressure.

⚠ CAUTION

Ensure bilge pump is operating before beginning procedures. Excess water in bilge can damage engine or cause boat to sink.

5. Turn on the bilge pump.

⚠ CAUTION

Do not run engine above 1300 rpm. Suction created by seawater pickup pump may collapse water supply hose, causing engine to overheat.

⚠ WARNING

Be certain the area around propeller is clear and no one is standing nearby. To avoid possible injury, remove propeller.

⚠ CAUTION

Watch temperature gauge on dash to ensure that engine does not overheat.

6. Start engine. Allow it to run at idle until the obstruction is cleared from the hose or for approximately 1 minute, whichever occurs first.
7. Shut off engine.
8. Shut off water supply to flushing attachment. Remove hose and flushing attachment.
9. Check for water draining from the blue drain hose. If blue drain hose is still clogged, shut off the bilge pump and reattach the blue drain hoses following Steps 7 - 9 in "3.0L Single Point Drain." The unit will need to be serviced by an authorized Mercury MerCruiser dealer. If water is draining, return to Step 3 of "3.0L Single Point Drain."

V6 And V8 Seawater (Raw-Water) Cooled Models

⚠ CAUTION

If boat is to remain in water after draining, seawater inlet hose must be removed and plugged to prevent a siphoning action that may occur, allowing seawater to flow from the drain holes or removed hoses.

IMPORTANT: Boat must be as level as possible to ensure complete draining of cooling system.

⚠ CAUTION

Seawater section of cooling system **MUST BE COMPLETELY** drained for winter storage, or immediately after cold weather use, if the possibility of freezing temperatures exists. Failure to comply may result in trapped water causing freeze and/or corrosion damage to engine. Damage caused by freezing **IS NOT** covered by the Mercury MerCruiser Limited Warranty.

1. Ensure engine is as level as possible to ensure complete draining of cooling system.
2. Remove drain plugs from the following locations, if equipped:
 - a. Port and starboard side of cylinder block.
 - b. Bottom of exhaust manifold(s).
 - c. Starboard side Y-fitting.
 - d. Fuel cooler.

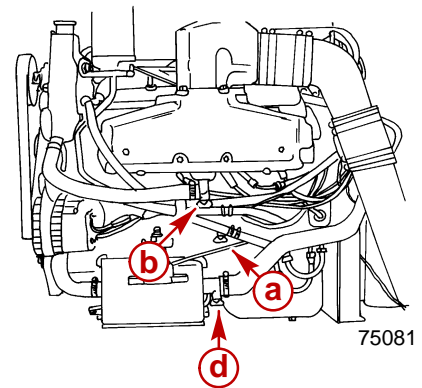
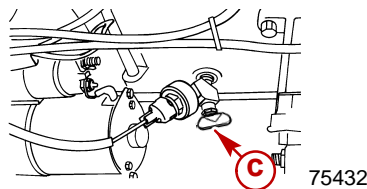

- a** - Cylinder Block Drain Plugs
- b** - Exhaust Manifold Drain Plugs
- c** - Y-Fitting Drain Plug
- d** - Fuel Cooler Drain Plug

3. Repeatedly clean out drain holes using a stiff piece of wire. Do this until entire system is drained.

NOTE: It may be necessary to lift or bend hoses to allow water to drain completely.

4. **Models equipped with circulating pump hose drain plug:** Remove drain plug.
5. **Models without circulating pump hose drain plug:** Loosen hose clamps and disconnect hose from thermostat housing or circulating pump. Allow water to drain.

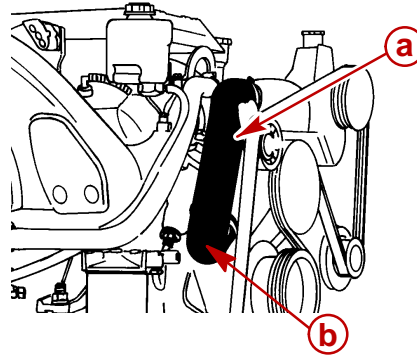

74774

- a** - Thermostat Housing To Circulating Pump Hose
- b** - Drain Plug Location, If Equipped

6. Make sure gear housing water vent and drain holes, speedometer pitot hole and trim tab cavity vent and drain holes are open and unobstructed.

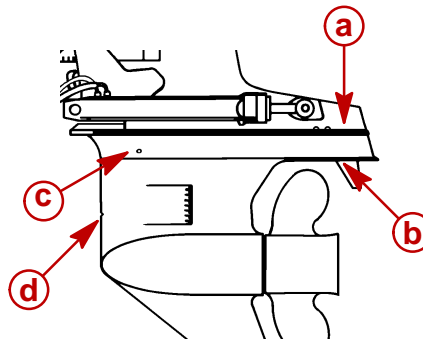

71216

- a** - Vent Holes
- b** - Trim Tab Cavity Drain Holes
- c** - Drain Hole
- d** - Speedometer Pitot Hole

7. Crank engine over slightly with starter motor to purge any water trapped in seawater pickup pump. Do not allow engine to start.
8. After cooling system has been drained completely, install drain plugs, reconnect hoses and tighten all hose clamps securely.

IMPORTANT: Mercury MerCruiser recommends that propylene glycol (a nontoxic and environmentally safe) antifreeze be used in the seawater section of the cooling system for cold weather or extended storage. Make sure that the propylene glycol antifreeze contains a rust inhibitor and is recommended for use in marine engines. Be certain to follow the propylene glycol manufacturer's recommendations.

9. For additional assurance against freezing and rust, fill the cooling system with a mixture of antifreeze and tap water mixed to manufacturer's recommendation to protect engine to the lowest temperature to which it will be exposed during cold weather or extended storage.
 - a. Remove thermostat housing or hose and fill with coolant until block and head are full. If thermostat housing was removed, reinstall and tighten cover bolts securely.

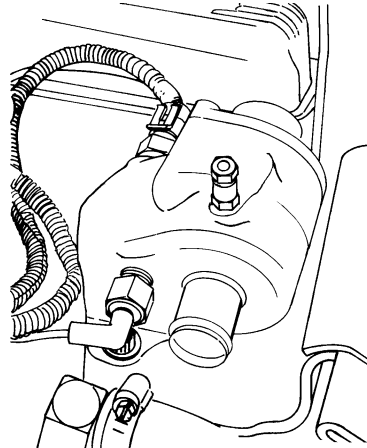

75598

- b. Remove water hose from exhaust manifold and fill manifold with coolant. Reinstall hose and tighten clamp securely.

Store boat with sterndrive unit in full DOWN/IN position.

V6 And V8 Closed Cooled Models

The following information outlines the procedures for draining the *seawater section* of the closed cooling systems.

IMPORTANT: Drain seawater section of closed cooling system only.

⚠ CAUTION

If boat is to remain in water after draining, seawater inlet hose must be removed and plugged to prevent a siphoning action that may occur allowing seawater to flow from the drain holes or removed hoses.

IMPORTANT: Boat must be as level as possible to ensure complete draining of cooling system.

⚠ CAUTION

Seawater section of cooling system **MUST BE COMPLETELY** drained for winter storage or immediately after cold weather use if the possibility of freezing temperatures exist. Failure to comply may result in trapped water causing freeze and/or corrosion damage to engine. Damage caused by freezing **IS NOT** covered by the Mercury MerCruiser Limited Warranty.

IMPORTANT: Closed cooling section must be kept filled year-round with recommended coolant. If engine will be exposed to freezing temperatures, make sure closed cooling section is filled with an ethylene glycol antifreeze and water solution properly mixed to protect engine to lowest temperature to which it will be exposed. Quicksilver Premixed Marine Engine Coolant is already mixed.

IMPORTANT: Do not use Propylene Glycol Antifreeze in the closed cooling section of the engine.

1. Ensure engine is as level as possible to ensure complete draining of cooling system.
2. Remove drain plug(s) from bottom of exhaust manifold(s).
3. Remove drain plug from fuel cooler.

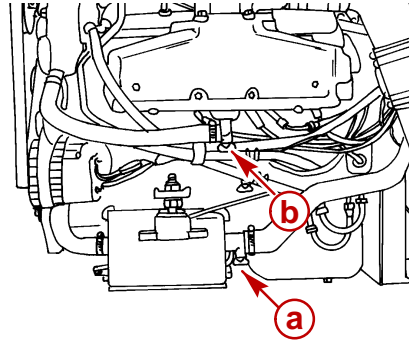

75039

- a** - Fuel Cooler Drain Plug
- b** - Exhaust Manifold Drain Plug(s)

4. Remove end caps, sealing washers and gaskets from heat exchangers.

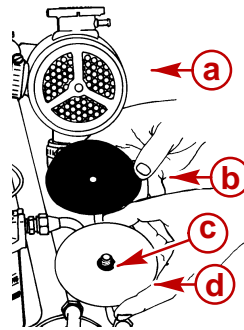

71515

- a** - Heat Exchanger
- b** - Gaskets
- c** - Sealing Washer
- d** - End Cap

5. Repeatedly clean out drain holes using a stiff piece of wire. Do this until entire system is drained.
6. On models with seawater pickup pump, loosen clamps and remove both hoses.

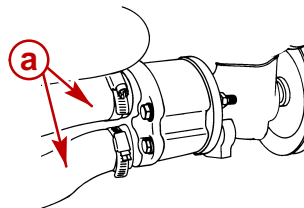

71170

- a** - Seawater Pickup Pump Hoses

7. Crank engine over slightly with starter motor to purge any water trapped in seawater pickup pump. DO NOT allow engine to start.
8. Make sure gear housing water vent and drain holes, speedometer pitot hole and trim tab cavity vent and drain holes are open and unobstructed.

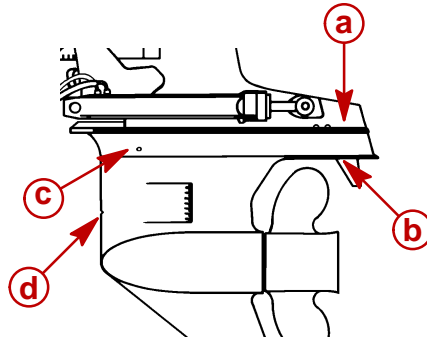

71216

- a** - Vent Holes
- b** - Trim Tab Cavity Drain Holes
- c** - Drain Hole
- d** - Speedometer Pitot Hole

9. After seawater section of cooling system has been drained completely, reinstall all components. Reconnect all hoses and tighten hose clamps securely.

All Models

1. For additional assurance against freezing and corrosion, fill the cooling system with a mixture of propylene glycol antifreeze and tap water mixed to manufacturer's recommendation to protect engine to the lowest temperature to which it will be exposed during cold weather or extended storage.
 - a. Remove thermostat housing or hose and fill with propylene glycol coolant until block and head are full. If thermostat housing was removed, reinstall and tighten cover bolts securely.

Store boat with drive unit in full DOWN/IN position.

THIS PAGE IS INTENTIONALLY BLANK

Wiring Diagrams

Instrumentation

SINGLE STATION INSTALLATIONS - TYPICAL

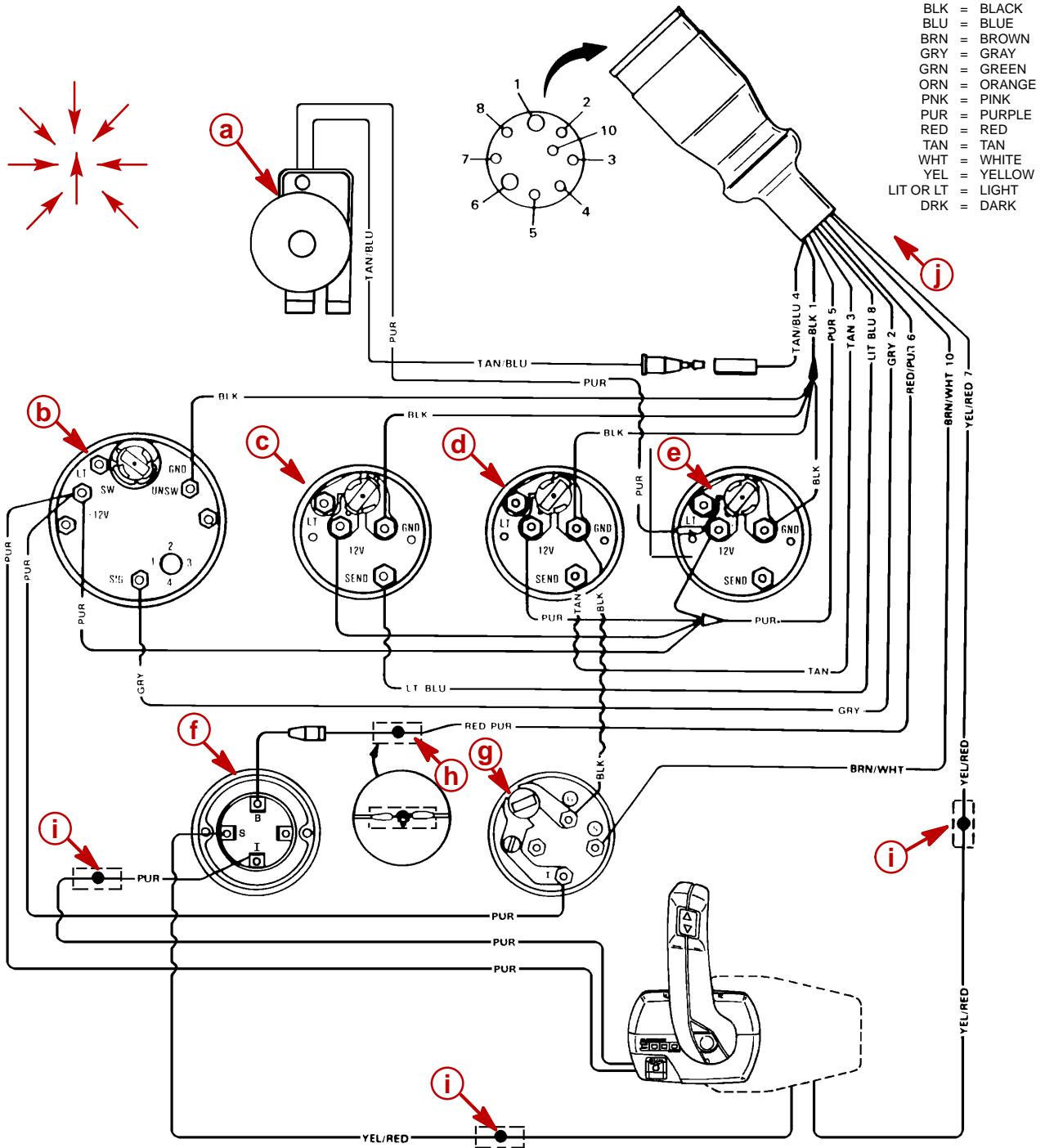

74583

Refer to gauge manufacturer's instructions for specific connections.

NOTE: ¹ Connect Wires Together with Screw and Hex Nut; Apply Liquid Neoprene to Connection and Slide Rubber Sleeve over Connection.

NOTE: ² Power for a Fused Accessory Panel May Be Taken from This Connection. Load Must Not Exceed 40 Amps. Panel Ground Wire Must Be Connected to Instrument Terminal That Has an 8-Gauge Black (Ground) Harness Wire Connected to it.

NOTE: ³ Lanyard stop switch lead and neutral safety switch leads must be soldered and covered with shrink tube for a water proof connection. If an alternate method of connection is made, verify connection is secure and sealed for a water proof connection.

- a** - Audio Warning Alarm
- b** - Tachometer
- c** - Oil Pressure
- d** - Water Temperature
- e** - Battery Meter
- f** - Ignition Switch
- g** - Trim Indicator
- h** - Read/Observe NOTE 1 and 2.
- i** - Read/Observe NOTE 3.
- j** - To Engine Wiring Harness

Power Trim System

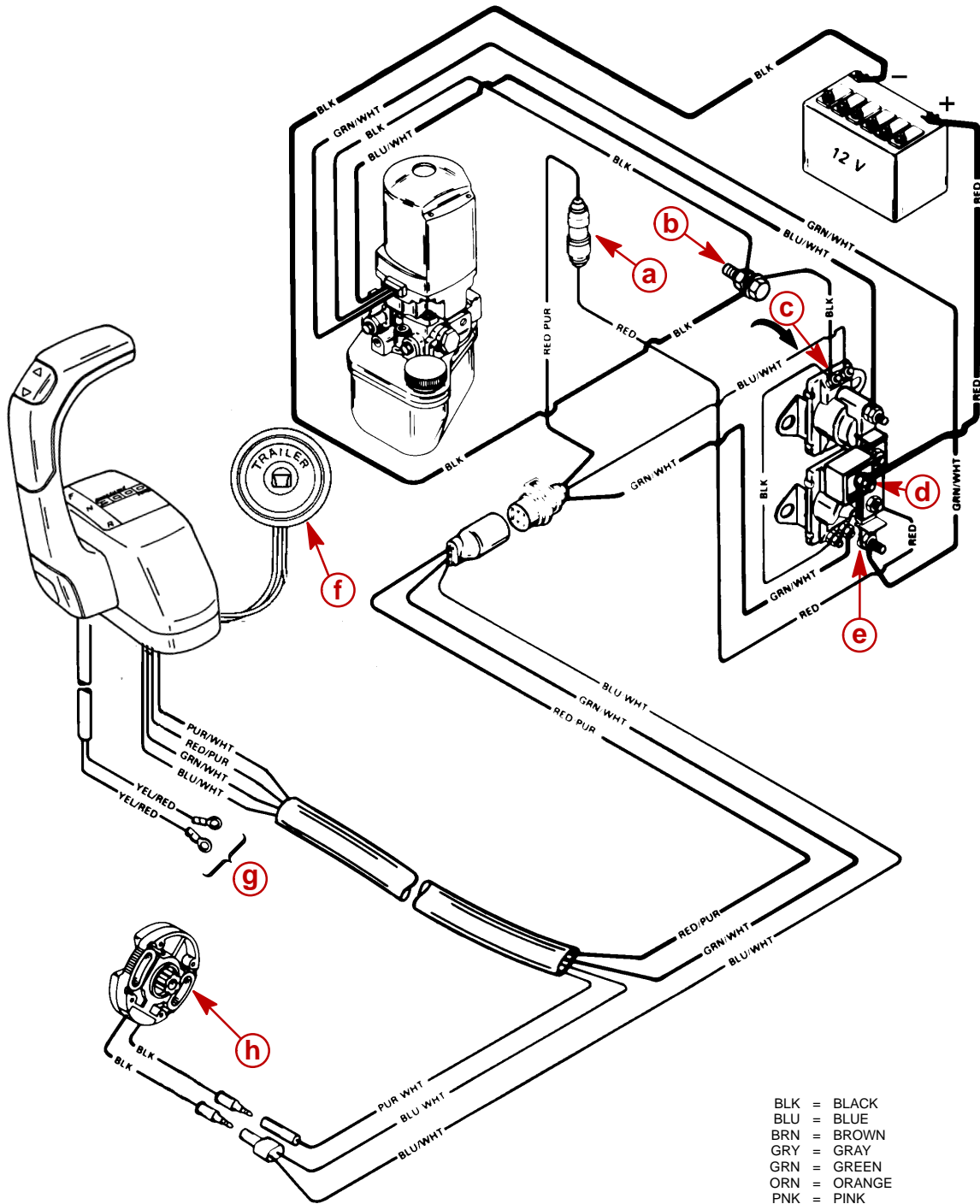

BLK = BLACK
 BLU = BLUE
 BRN = BROWN
 GRY = GRAY
 GRN = GREEN
 ORN = ORANGE
 PNK = PINK
 PUR = PURPLE
 RED = RED
 TAN = TAN
 WHT = WHITE
 YEL = YELLOW
 LT OR LIT = LIGHT
 DRK = DARK

73962

- a** - 20 Amp Fuse
- b** - Ground Bolt (Floor Mount)
- c** - UP Solenoid
- d** - 110 Amp Fuse
- e** - DOWN Solenoid
- f** - Trailer Switch
- g** - Neutral Switch to Instrument Wiring Harness
- h** - Trim Limit Switch

MerCathode System Wiring Diagram

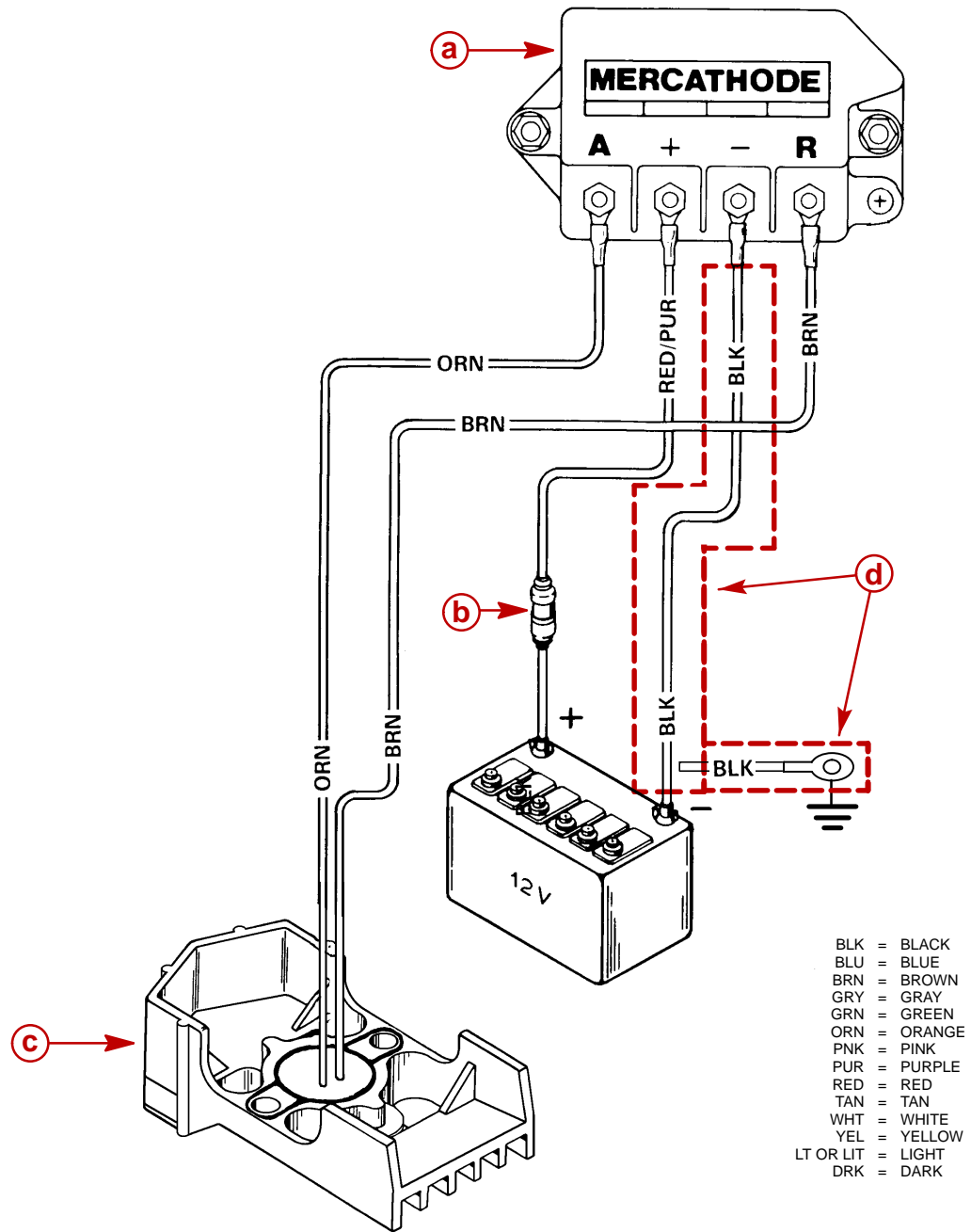

- a** - Controller
- b** - 20 Amp Fuse
- c** - Electrode
- d** - BLACK Wire - With Engine Harness or Separate

73596

MCM Gasoline Engine Wiring Diagrams

3.0L Engines

- BLK = BLACK
- BLU = BLUE
- BRN = BROWN
- GRY = GRAY
- GRN = GREEN
- ORN = ORANGE
- PNK = PINK
- PUR = PURPLE
- RED = RED
- TAN = TAN
- WHT = WHITE
- YEL = YELLOW
- LIT = LIGHT
- DRK = DARK

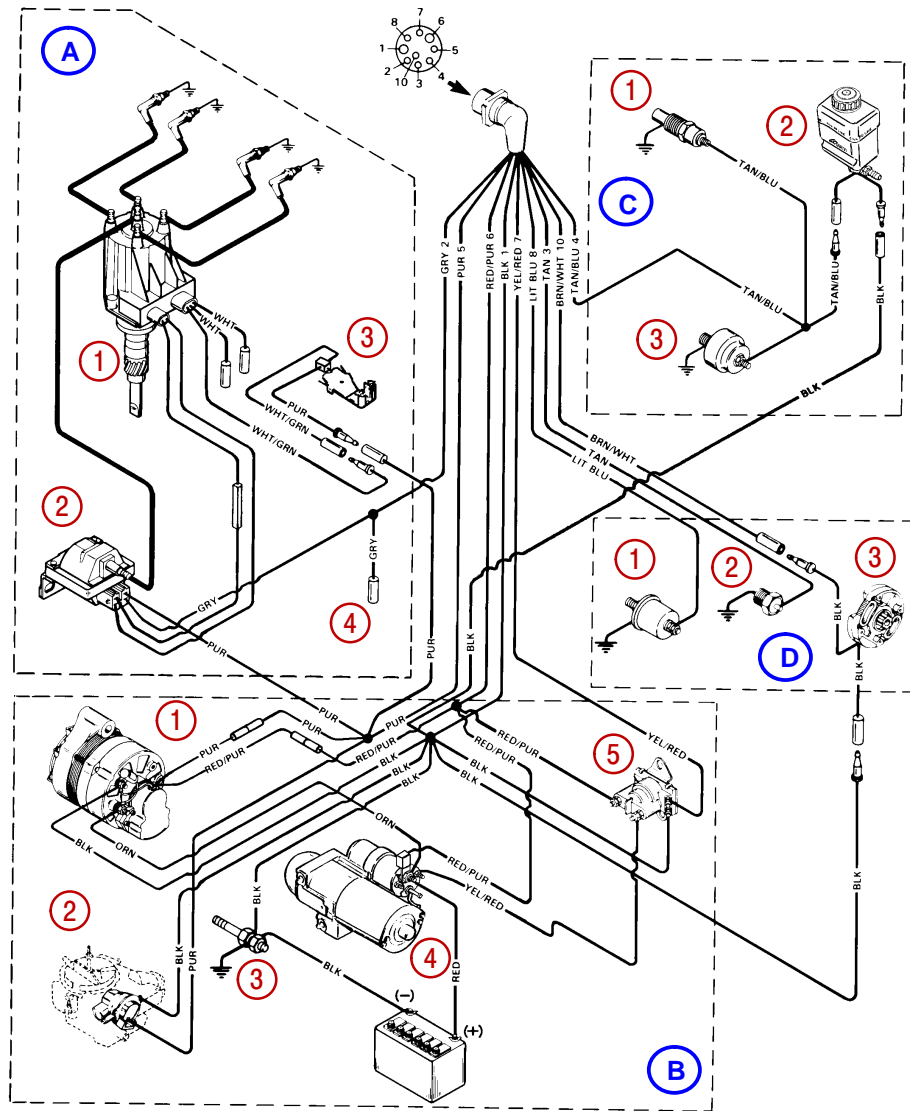

75567

A - Ignition Components

- 1 - Distributor
- 2 - Ignition Coil
- 3 - Shift Cutout Switch
- 4 - GRAY lead for use with Service Tachometer.

B - Starting, Charging and Choke Components

- 1 - Alternator
- 2 - Electric Choke
- 3 - Ground Stud
- 4 - Starter Motor
- 5 - Starter Slave Solenoid

C - Audio Warning Components

- 1 - Water Temperature
- 2 - Drive Unit Gear Lube Monitor
- 3 - Oil Pressure Switch

D - Instrumentation Components

- 1 - Oil Pressure Sender
- 2 - Water Temperature Sender
- 3 - Trim Sender

MCM 4.3L, 5.0L And 5.7L Alpha Engines

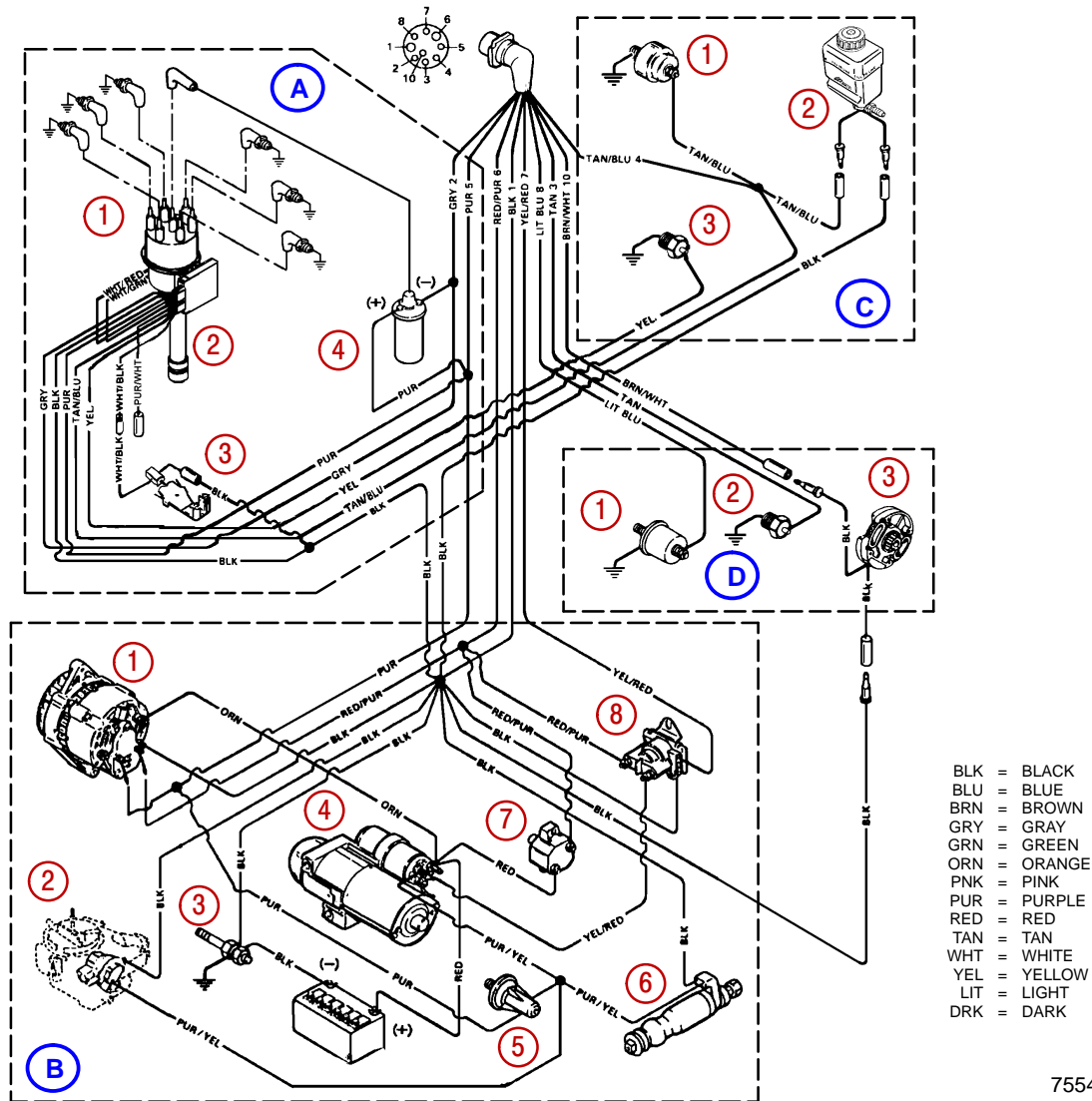

75547

A - Ignition Components

- 1 - Distributor
- 2 - Timing Lead
- 3 - Shift Cutout
- 4 - Ignition Coil

B - Starting, Charging and Choke Components

- 1 - Alternator
- 2 - Electric Choke
- 3 - Ground Stud
- 4 - Starter Motor
- 5 - Oil Pressure Switch
- 6 - Fuel Pump
- 7 - Circuit Breaker
- 8 - Starter Slave Solenoid

C - Audio Warning Components

- 1 - Oil Pressure Switch
- 2 - Drive Unit Gear Lube Monitor
- 3 - Water Temperature Sender

D - Instrumentation Components

- 1 - Oil Pressure Sender
- 2 - Water Temperature Sender
- 3 - Trim Sender

MCM 4.3L Bravo Engines

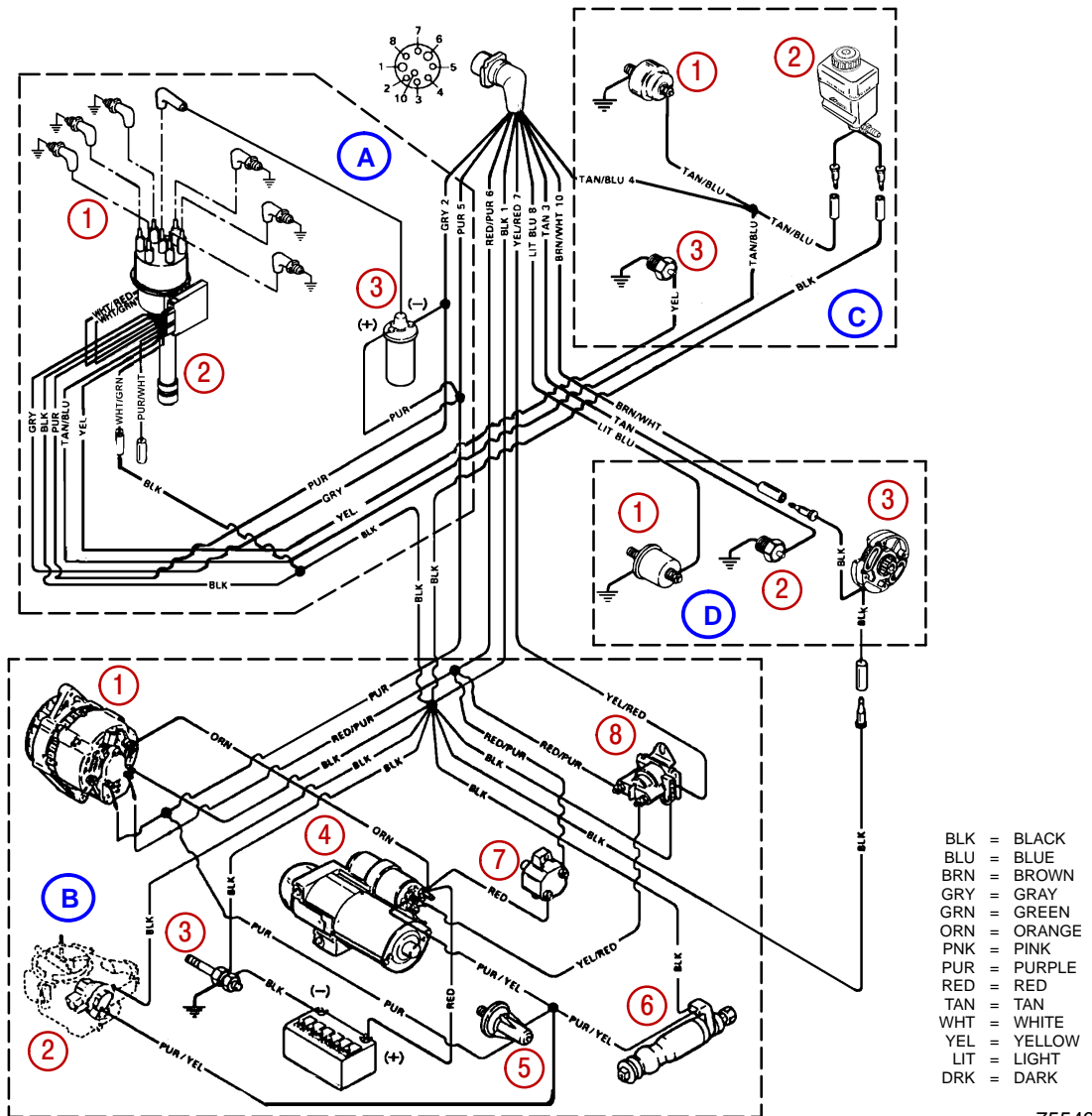

75549

A - Ignition Components

- 1 - Distributor
- 2 - Timing Lead
- 3 - Ignition Coil

B - Starting, Charging and Choke Components

- 1 - Alternator
- 2 - Electric Choke
- 3 - Ground Stud
- 4 - Starter Motor
- 5 - Oil Pressure Switch
- 6 - Fuel Pump
- 7 - Circuit Breaker
- 8 - Starter Slave Solenoid

C - Audio Warning Components

- 1 - Oil Pressure Switch
- 2 - Drive Unit Gear Lube Monitor
- 3 - Water Temperature Sender

D - Instrumentation Components

- 1 - Oil Pressure Sender
- 2 - Water Temperature Sender
- 3 - Trim Sender

MCM 5.0L and 5.7L Bravo Engines

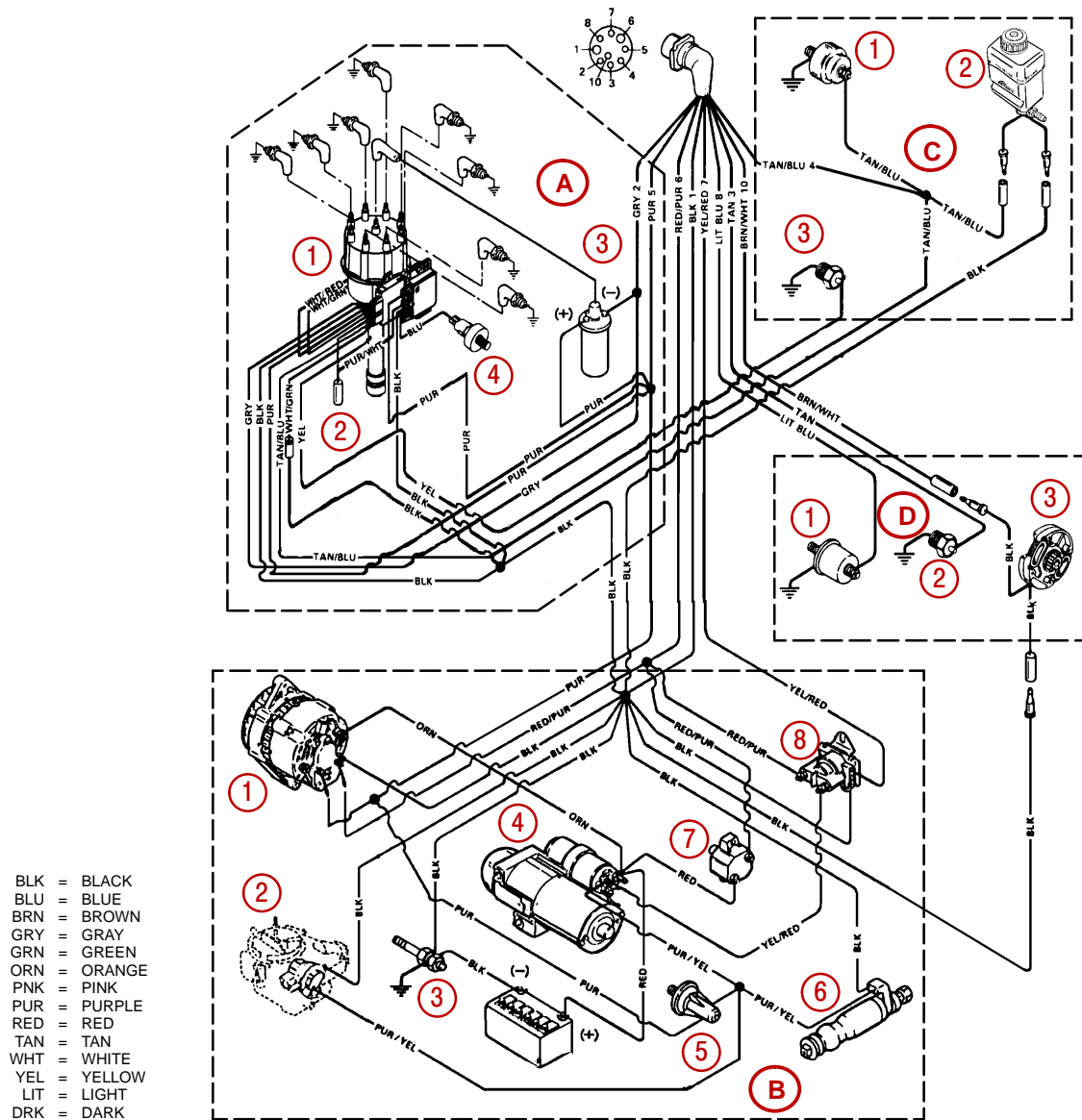

75550

A - Ignition Components

- 1 - Distributor
- 2 - Timing Lead
- 3 - Ignition Coil
- 4 - Knock Sensor

B - Starting, Charging and Choke Components

- 1 - Alternator
- 2 - Electric Choke
- 3 - Ground Stud
- 4 - Starter Motor
- 5 - Oil Pressure Switch
- 6 - Fuel Pump
- 7 - Circuit Breaker
- 8 - Starter Slave Solenoid

C - Audio Warning Components

- 1 - Oil Pressure Switch
- 2 - Drive Unit Gear Lube Monitor
- 3 - Water Temperature Sender

D - Instrumentation Components

- 1 - Oil Pressure Sender
- 2 - Water Temperature Sender
- 3 - Trim Sender

Water Flow Diagrams

181 cid / 3.0L Engines

- 1 - Engine Circulating Pump
- 2 - Thermostat Housing
- 3 - Intake and Exhaust Manifolds
- 4 - Exhaust Elbow
- 5 - Power Steering Cooler (If Equipped)
- 6 - Seawater Intake (From Sterndrive)
- 7 - Engine Block and Cylinder Head Assembly

“A” Water Flow With Thermostat Closed

“B” Water Flow With Thermostat Open

- a - To Exhaust Manifold
- b - To Engine Circulating Pump
- c - Inlet From Sterndrive
- d - From Block and Cylinder Head

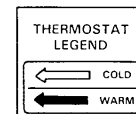
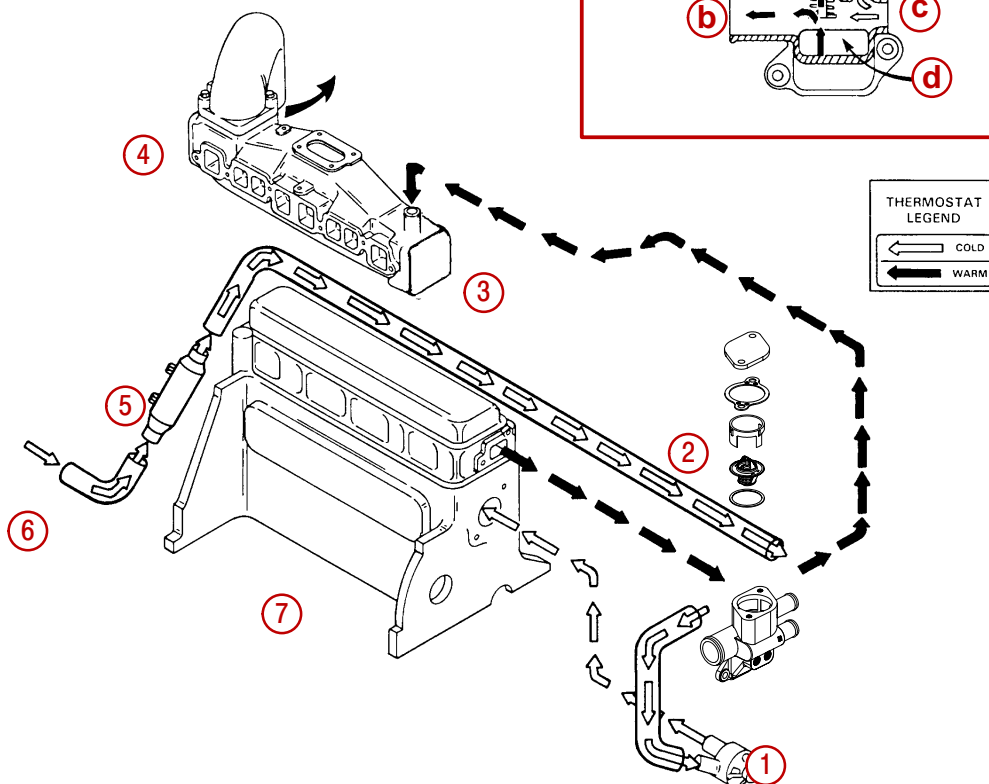
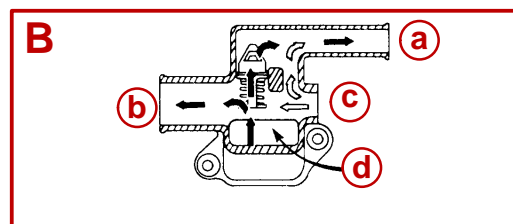
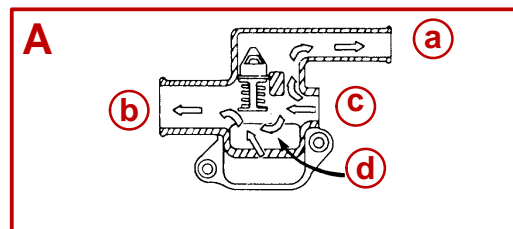

76279

V8 Engines - Seawater Cooled

262 CID, 305 CID AND 350 CID ENGINES

NOTE: Certain components in the following diagram may look different than on your particular power package, but the water flow paths remain similar on all engines.

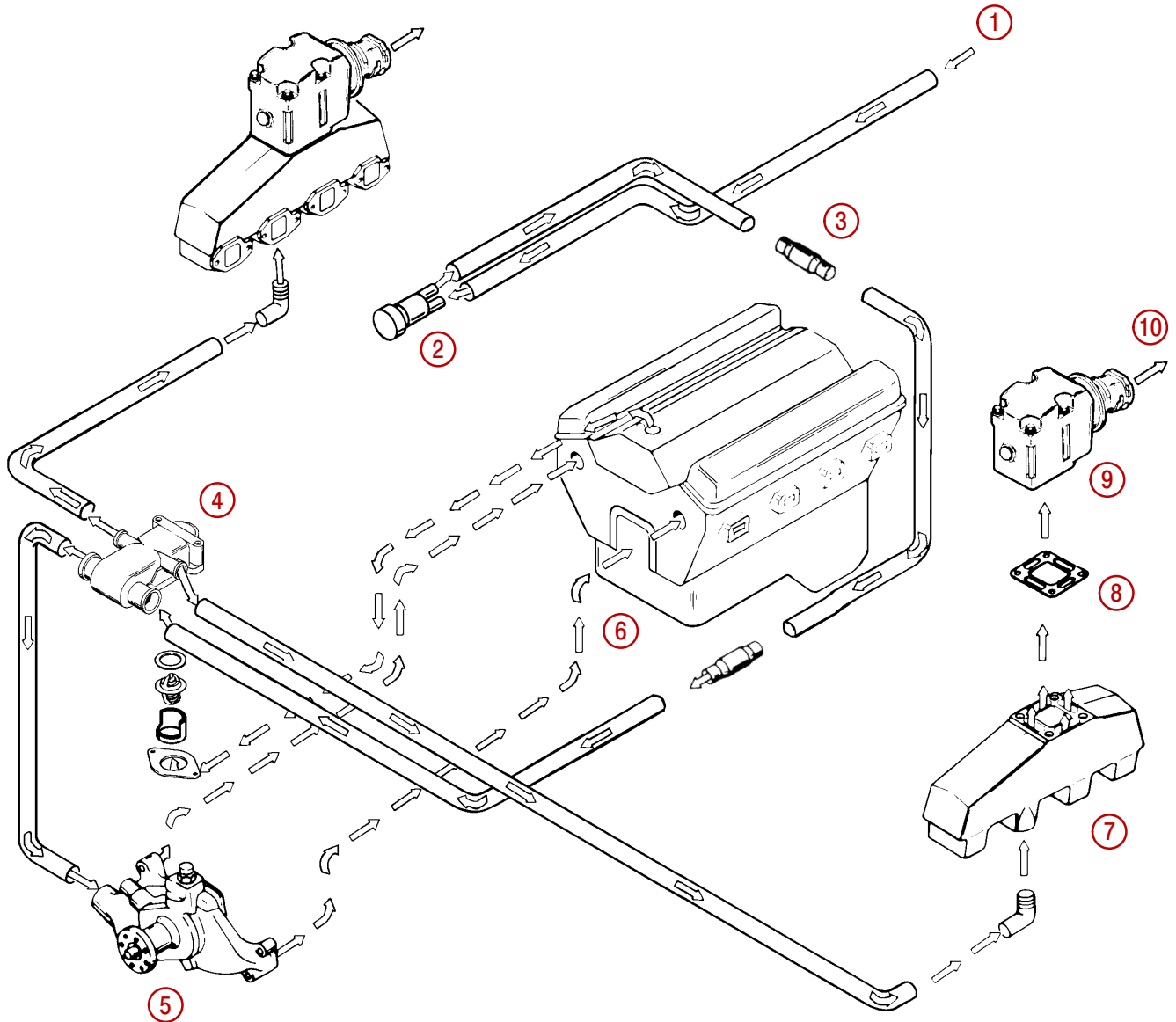

77992

- 1** - Seawater Intake (From Sterndrive)
- 2** - Seawater Pump (Bravo Models)
- 3** - Power Steering Cooler, If Equipped
- 4** - Thermostat Housing and Cover Assembly
- 5** - Engine Water Circulating Pump
- 6** - Engine Block and Cylinder Head Assembly
- 7** - Exhaust Manifold, Typical
- 8** - Restrictor Gasket
- 9** - Exhaust Elbow Assembly, Typical
- 10** - Water Flow Overboard

V6 and V8 Engines - Closed Cooled

NOTE: Certain components in the following diagram may look different than on your particular power package, but the water and coolant flow paths remain similar on all engines.

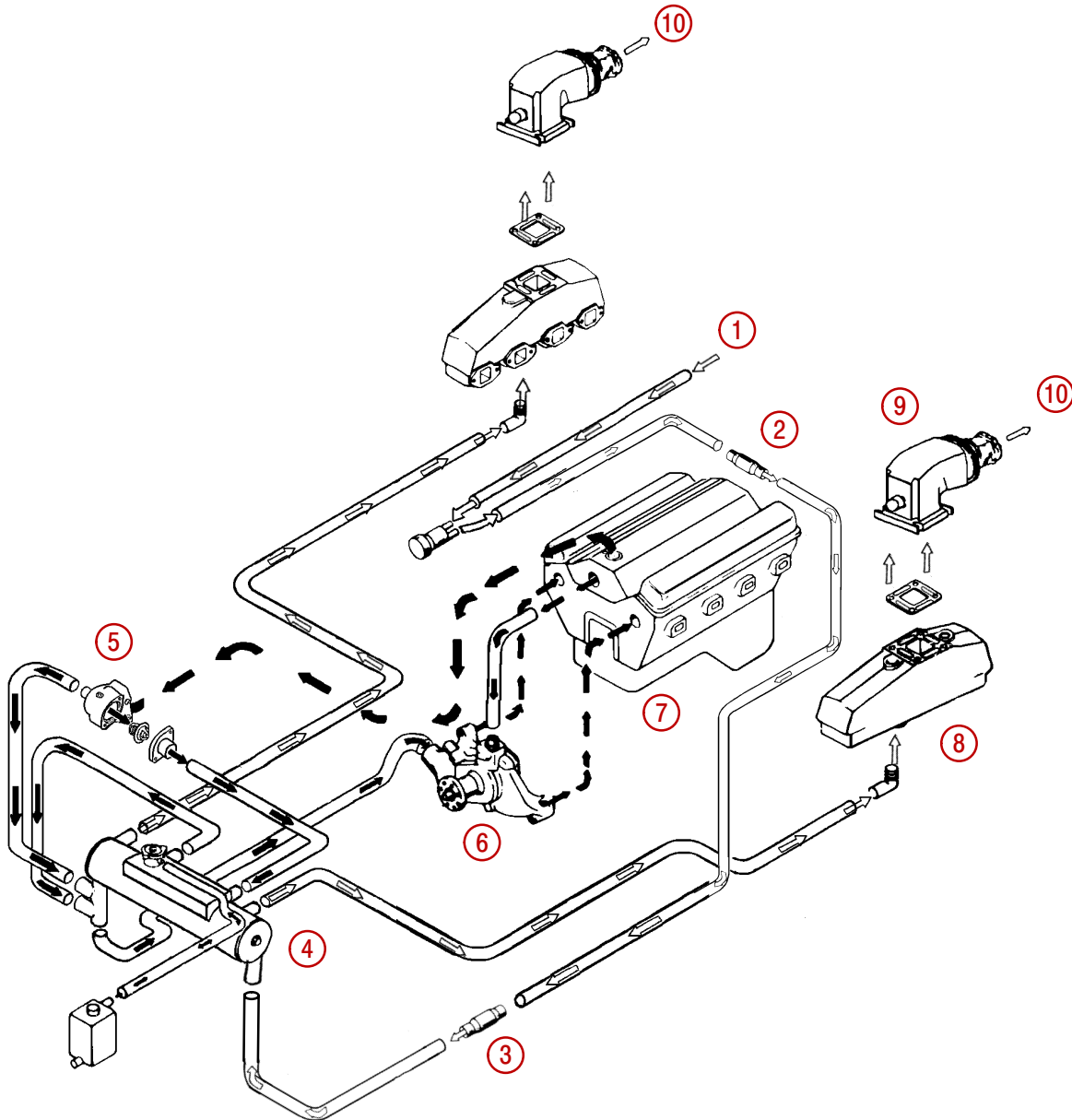

75005

- 1** - Seawater Intake (From Sterndrive)
- 2** - Power Steering Cooler
- 3** - Fuel Cooler, If Equipped
- 4** - Heat Exchanger, Typical
- 5** - Thermostat Housing and Cover Assembly
- 6** - Engine Water Circulating Pump
- 7** - Engine Block and Cylinder Head Assembly
- 8** - Exhaust Manifold, Typical
- 9** - Exhaust Elbow Assembly, Typical
- 10** - Overboard (Water and Exhaust Discharge)

Predelivery Inspection

Not Applicable	Check/ Adjust		Not Applicable	Check/ Adjust	
CHECK BEFORE RUNNING			ON THE WATER TEST		
<input type="checkbox"/>	<input type="checkbox"/>	Drain plug in and petcocks closed	<input type="checkbox"/>	<input type="checkbox"/>	Engine alignment (Inboards only)
<input type="checkbox"/>	<input type="checkbox"/>	Seawater inlet valve open	<input type="checkbox"/>	<input type="checkbox"/>	Starter neutral safety switch operation
<input type="checkbox"/>	<input type="checkbox"/>	Engine mounts tight	<input type="checkbox"/>	<input type="checkbox"/>	Water pump operation
<input type="checkbox"/>	<input type="checkbox"/>	Engine alignment	<input type="checkbox"/>	<input type="checkbox"/>	Instruments(s) operation
<input type="checkbox"/>	<input type="checkbox"/>	Drive unit fasteners torqued	<input type="checkbox"/>	<input type="checkbox"/>	Fuel leaks
<input type="checkbox"/>	<input type="checkbox"/>	Power trim cylinders fasteners tight	<input type="checkbox"/>	<input type="checkbox"/>	Oil leaks
<input type="checkbox"/>	<input type="checkbox"/>	Battery fully charged and secured	<input type="checkbox"/>	<input type="checkbox"/>	Water leaks
<input type="checkbox"/>	<input type="checkbox"/>	All electrical connections tight	<input type="checkbox"/>	<input type="checkbox"/>	Exhaust leaks
<input type="checkbox"/>	<input type="checkbox"/>	Exhaust system hose clamps tight	<input type="checkbox"/>	<input type="checkbox"/>	Ignition timing
<input type="checkbox"/>	<input type="checkbox"/>	All fuel connections tight	<input type="checkbox"/>	<input type="checkbox"/>	Idle_____rpm, within specifications
<input type="checkbox"/>	<input type="checkbox"/>	Correct rotation propeller (installed and torqued)	<input type="checkbox"/>	<input type="checkbox"/>	FORWARD - NEUTRAL - REVERSE gear operation
<input type="checkbox"/>	<input type="checkbox"/>	Throttle, shift and steering system fasteners tightened properly	<input type="checkbox"/>	<input type="checkbox"/>	Steering operation throughout range
<input type="checkbox"/>	<input type="checkbox"/>	Throttle plates open and close completely	<input type="checkbox"/>	<input type="checkbox"/>	Acceleration from idle rpm
<input type="checkbox"/>	<input type="checkbox"/>	Crankcase oil level	<input type="checkbox"/>	<input type="checkbox"/>	WOT_____rpm within specifications (in FORWARD gear)
<input type="checkbox"/>	<input type="checkbox"/>	Power trim oil level	<input type="checkbox"/>	<input type="checkbox"/>	Power trim operation
<input type="checkbox"/>	<input type="checkbox"/>	Stern drive unit oil level	<input type="checkbox"/>	<input type="checkbox"/>	Trim tab adjustment
<input type="checkbox"/>	<input type="checkbox"/>	Power steering fluid level	<input type="checkbox"/>	<input type="checkbox"/>	Boat handling
<input type="checkbox"/>	<input type="checkbox"/>	Closed cooling level	AFTER ON WATER TEST		
<input type="checkbox"/>	<input type="checkbox"/>	Transmission fluid level	<input type="checkbox"/>	<input type="checkbox"/>	Propeller nut torque
<input type="checkbox"/>	<input type="checkbox"/>	Alternator belt tension	<input type="checkbox"/>	<input type="checkbox"/>	Fuel, oil, coolant, water and fluid leaks
<input type="checkbox"/>	<input type="checkbox"/>	Seawater pickup pump belt tension	<input type="checkbox"/>	<input type="checkbox"/>	Oil and fluid levels
<input type="checkbox"/>	<input type="checkbox"/>	Power steering pump belt tension	<input type="checkbox"/>	<input type="checkbox"/>	Apply Quicksilver Corrosion Guard to engine package
<input type="checkbox"/>	<input type="checkbox"/>	Audio warning system operation	<input type="checkbox"/>	<input type="checkbox"/>	